



THERMIA® AF35

La ventana básica y eficaz.

THERMIA®
BARCELONA

Ventanas para vivir mejor

PERMEABILIDAD AL AIRE según EN 12207 - Mercado CE según EN 14351-1:2006 (E.1)

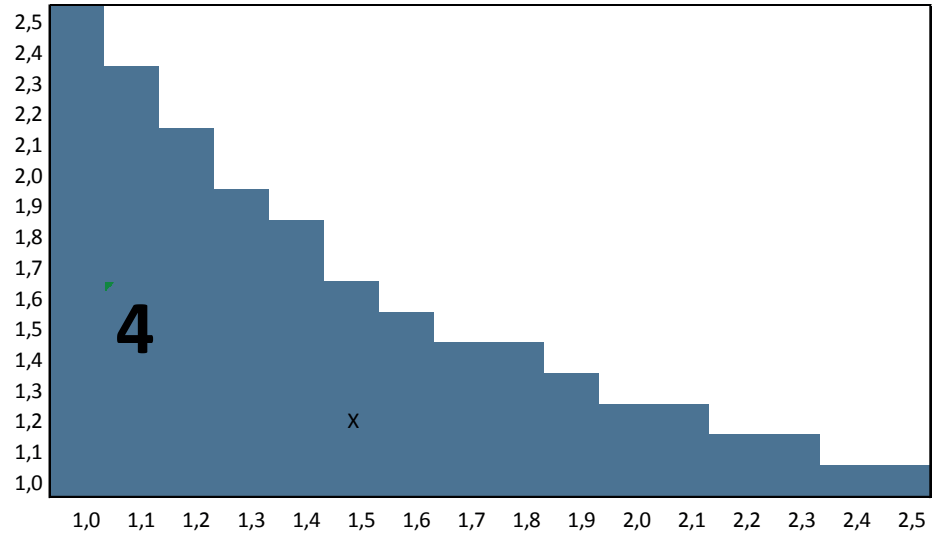

ESTANQUIDAD AL AGUA según EN 12208 - Mercado CE según EN 14351-1:2006 (E.1)

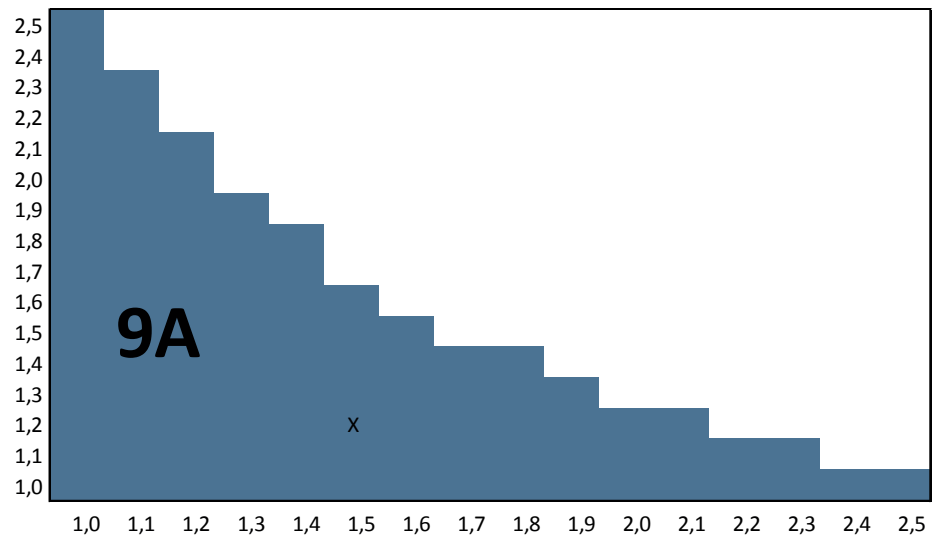

RESISTENCIA AL VIENTO según EN 12210 - Mercado CE según EN 14351-1:2006 (E.1)

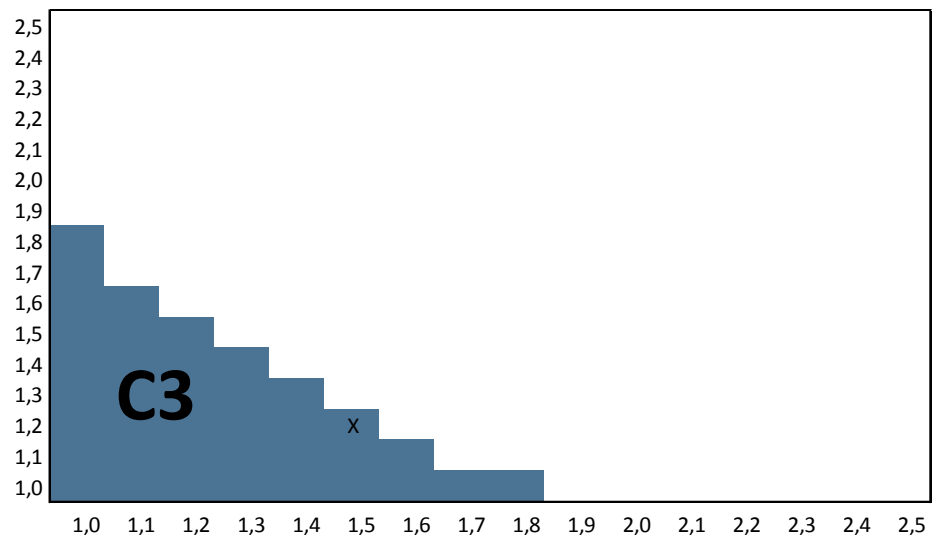

Resultados obtenidos del informe oficial num.: 15/10169-753 según ensayos realizados en Applus, y en base al Anexo E de la norma EN 14351-1:2006.

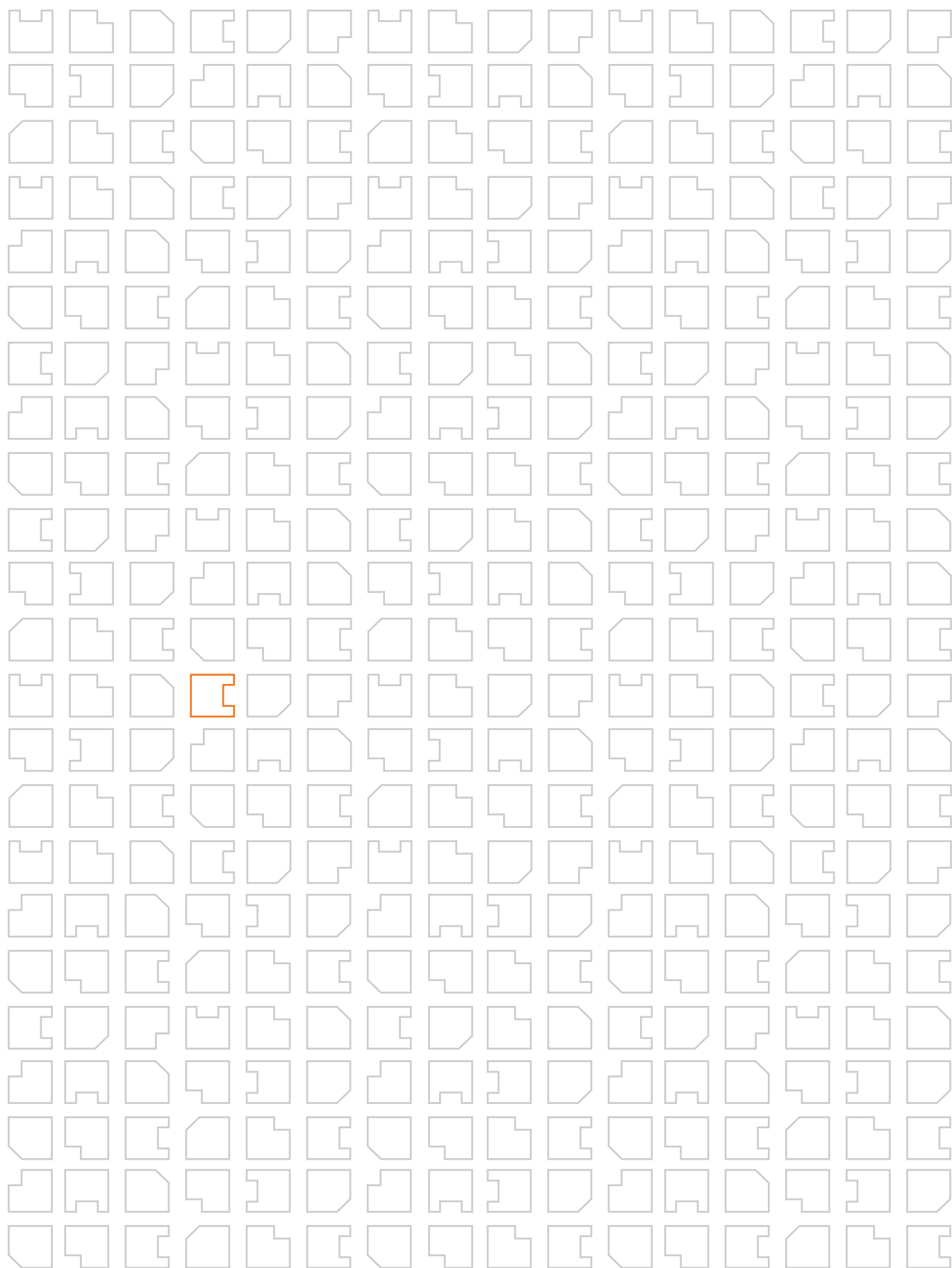

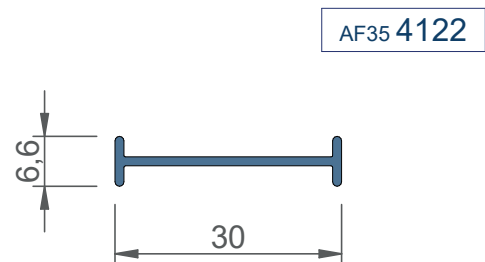
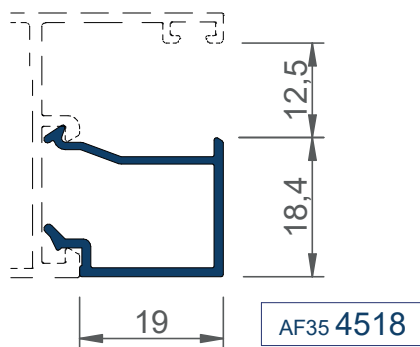
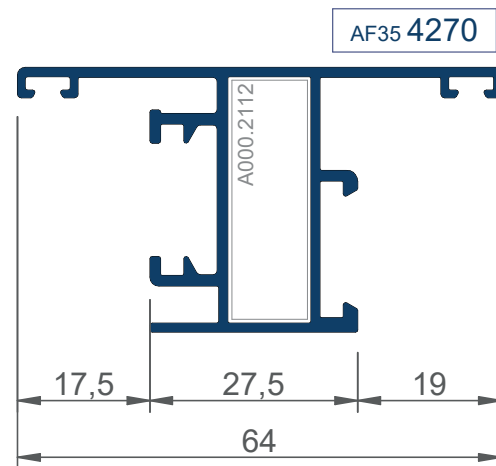
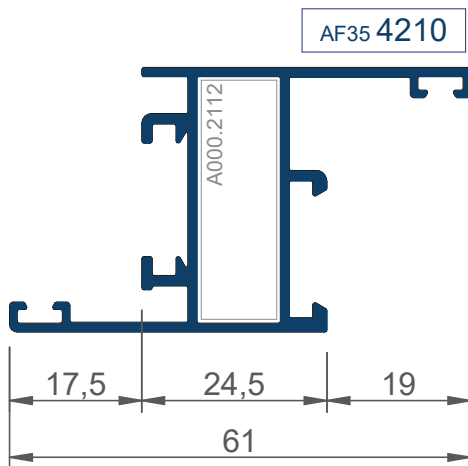
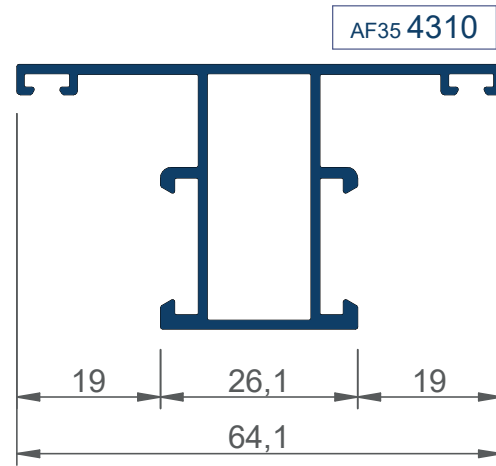
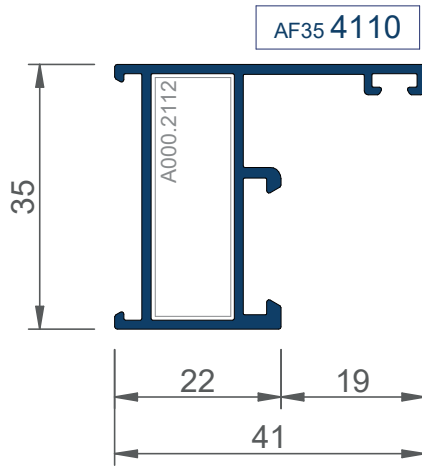

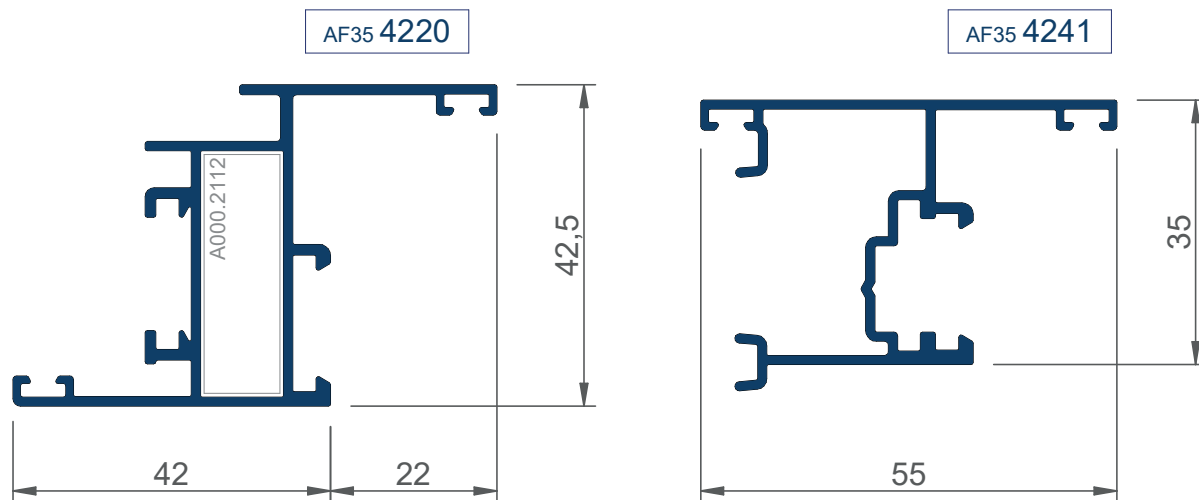

junquillos altura 22

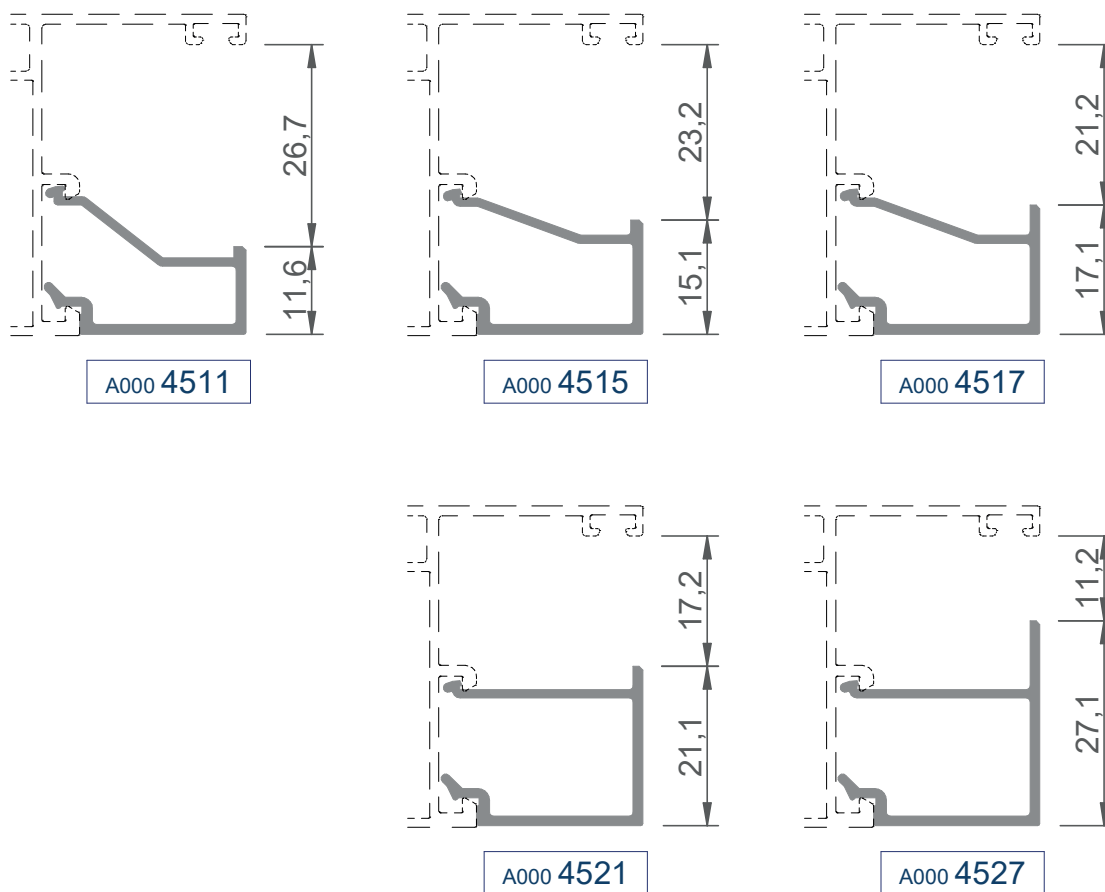



A000 2112

escuadra



A000 2120

unión travesaño



A000 2320

junta cierre

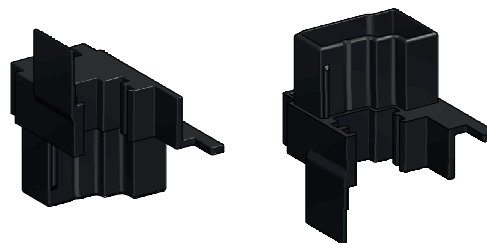

AF35 2340

juego tapas inversora



A000 2351

junta exterior (2mm)



A000 2353

junta cuña (de 3 a 5mm)



A000 2355

junta cuña (de 5 a 7mm)

Para accesorios de Maniobra consultar catálogo específico

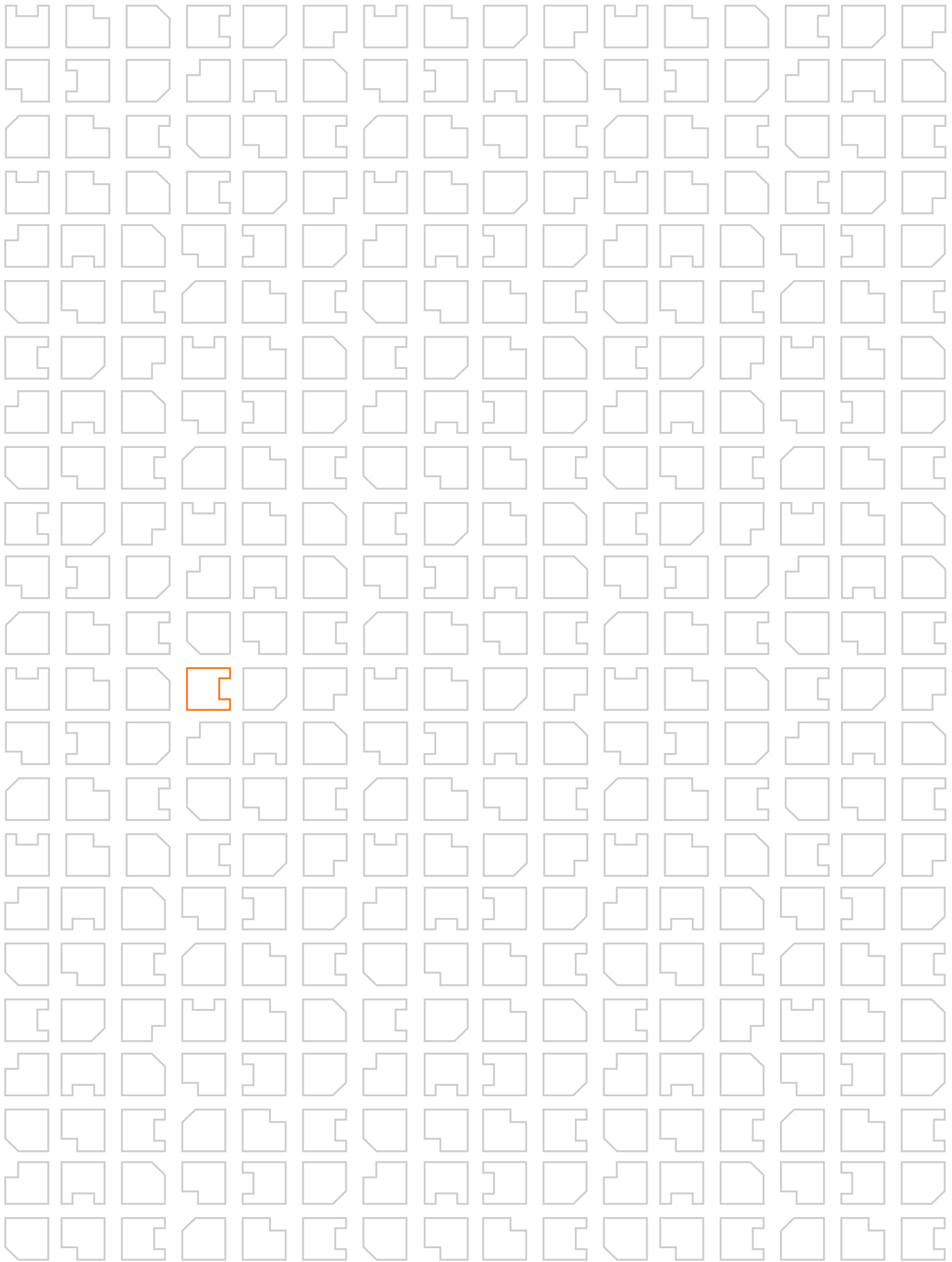

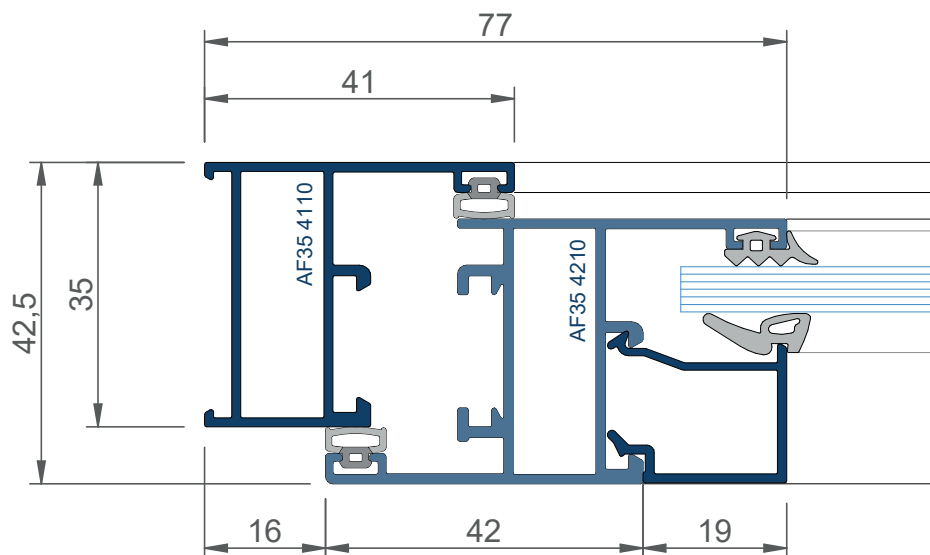

apertura interior

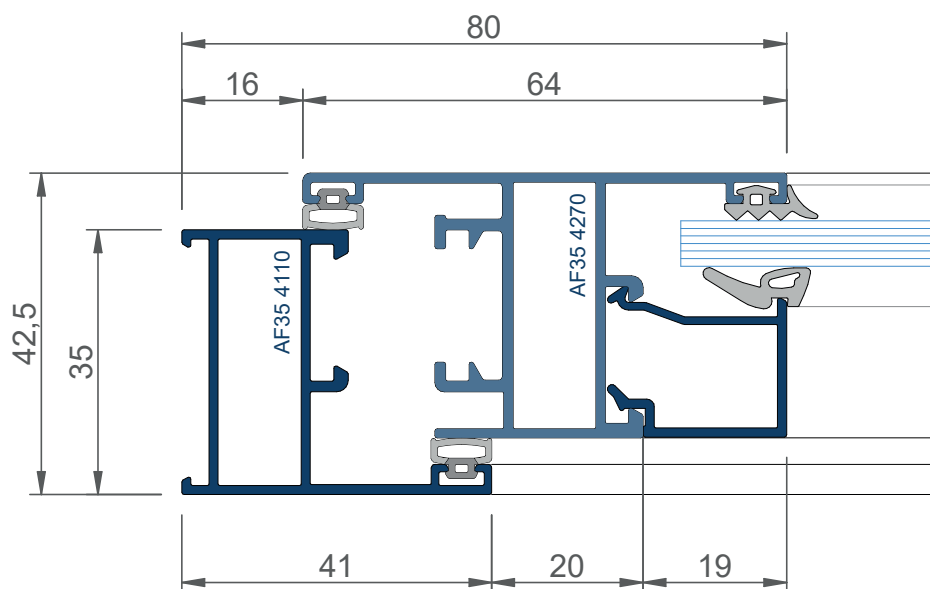

apertura exterior

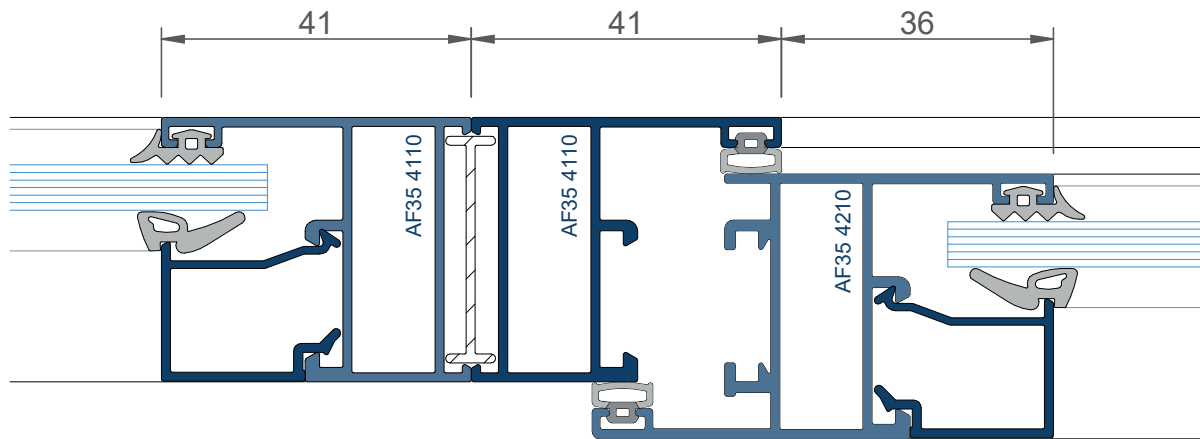

apertura interior

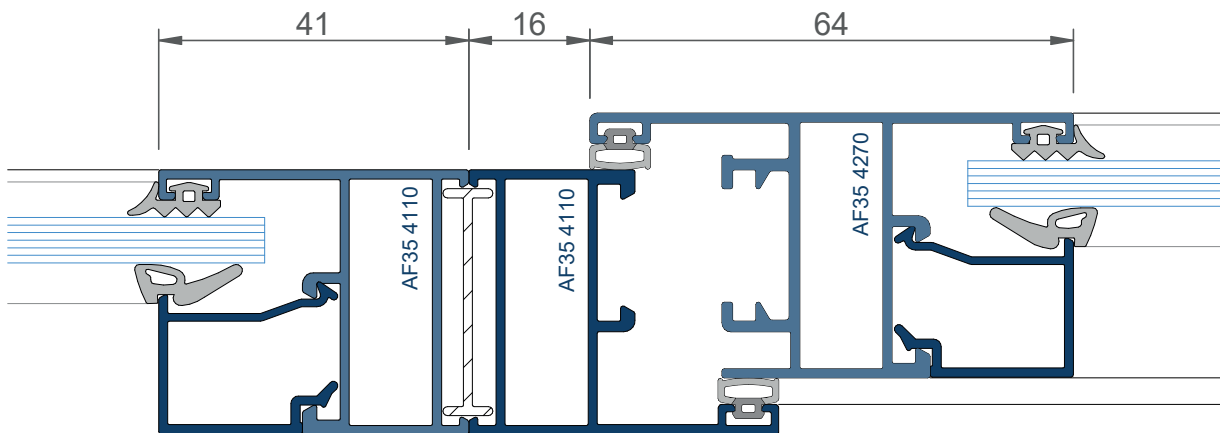

apertura exterior

con junquillos alt 22mm

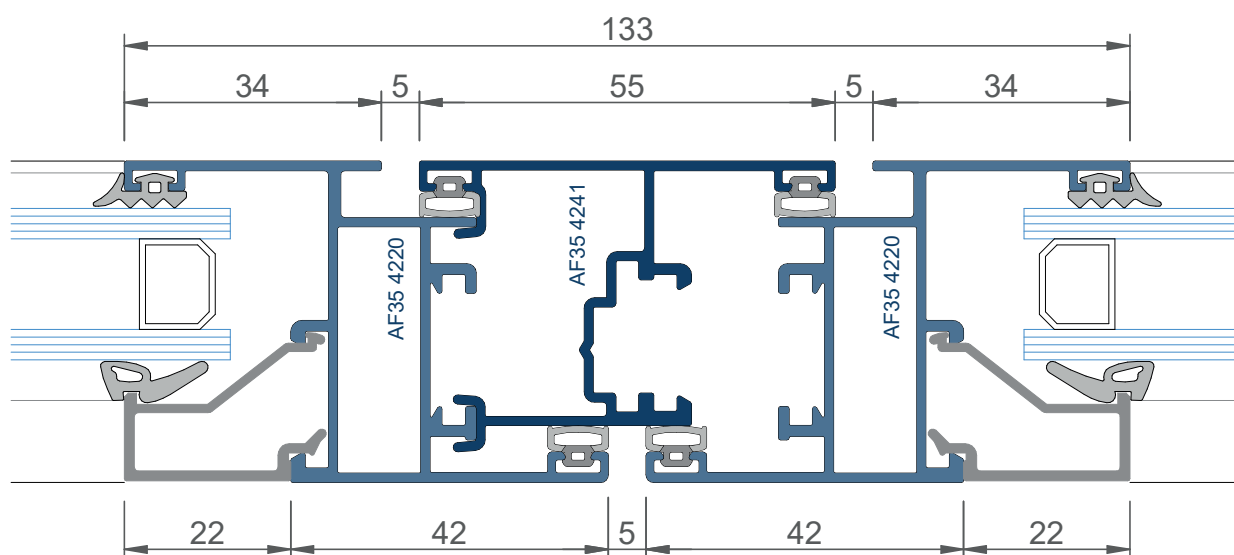
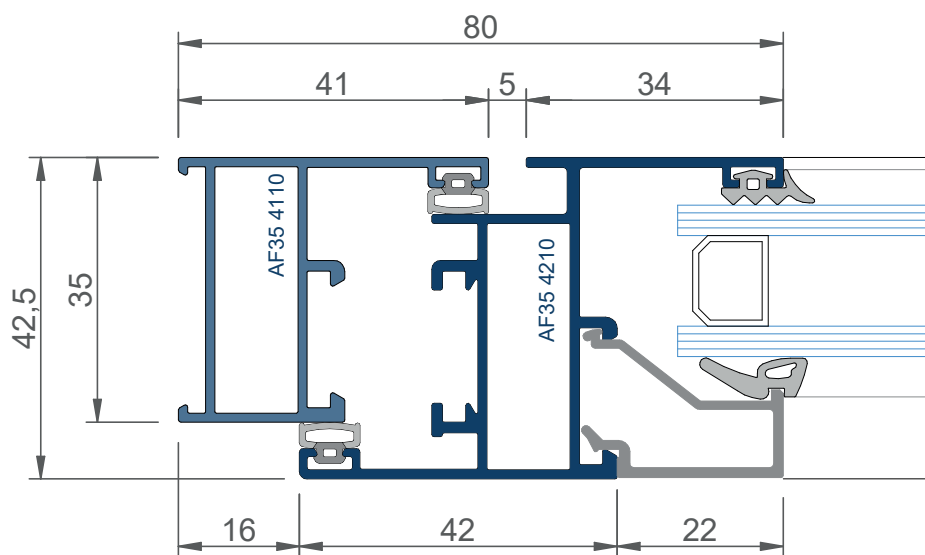

combinada con **CF22**

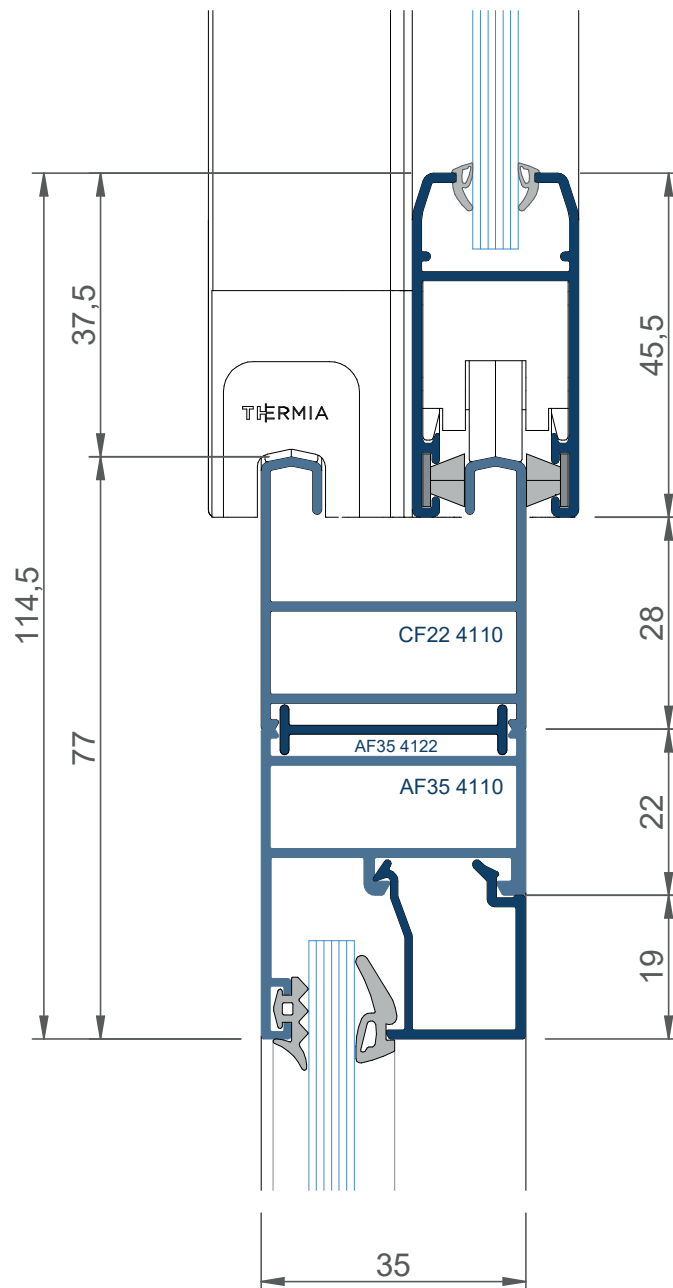
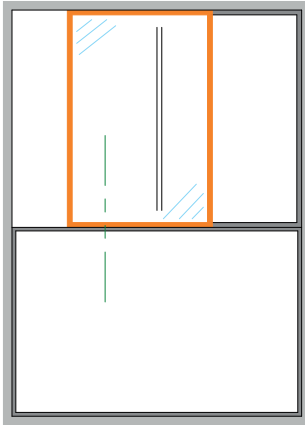

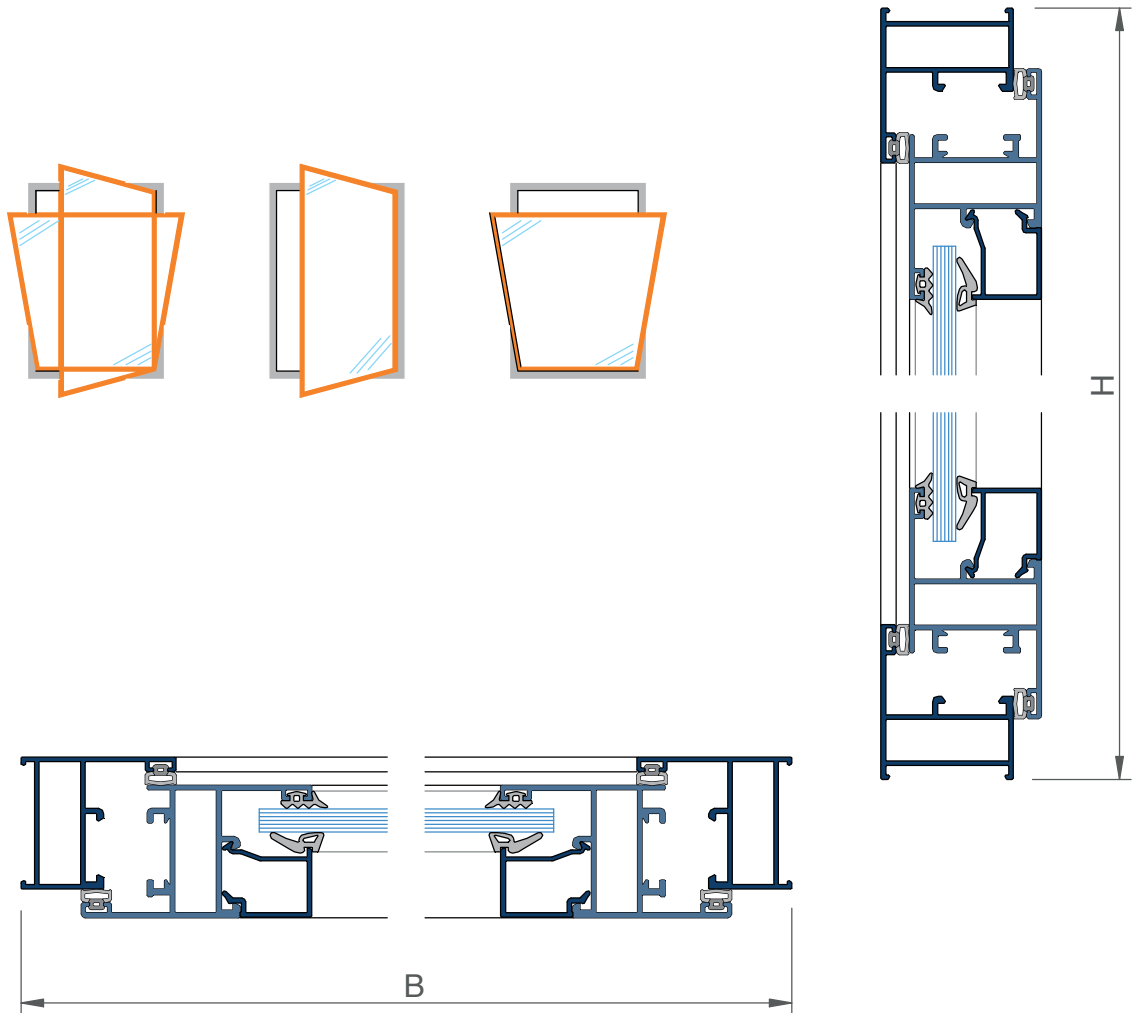

COD	DESCRIPCIÓN	CANT	FORMULA
AF35 4110	marco horizontal	2	B
AF35 4110	marco vertical	2	H
AF35 4210	hoja horizontal	2	B-33
AF35 4210	hoja vertical	2	H-33
AF35 4518	junquillo horizontal	2	B-116
AF35 4518	junquillo vertical	2	H-154
vidrio		1	B-125 x H-125
A000 2112	escuadras	8	
A000 2320	junta cierre	4	B+H
A000 2351	junta ext vidrio	2	B+H
A000 2....	junta int vidrio	2	B+H

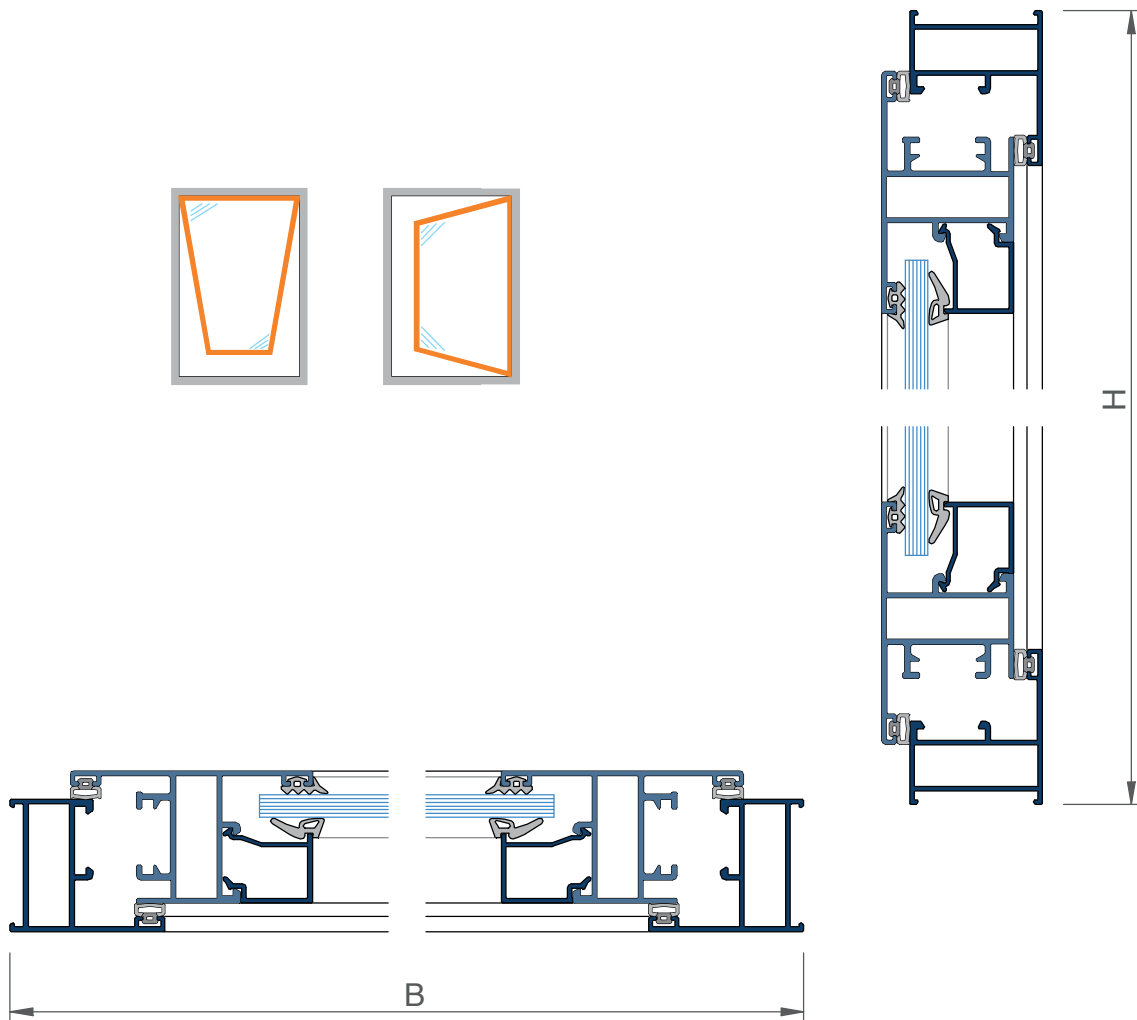

COD	DESCRIPCIÓN	CANT	FORMULA
AF35 4110	marco horizontal	2	B
AF35 4110	marco vertical	2	H
AF35 4270	hoja EXT horizontal	2	B-33
AF35 4270	hoja EXT vertical	2	H-33
AF35 4518	junquillo horizontal	2	B-122
AF35 4518	junquillo vertical	2	H-160
vidrio		1	B-132 x H-132
A000 2112	escuadras	8	
A000 2320	junta cierre	4	B+H
A000 2351	junta ext vidrio	2	B+H
A000 2....	junta int vidrio	2	B+H

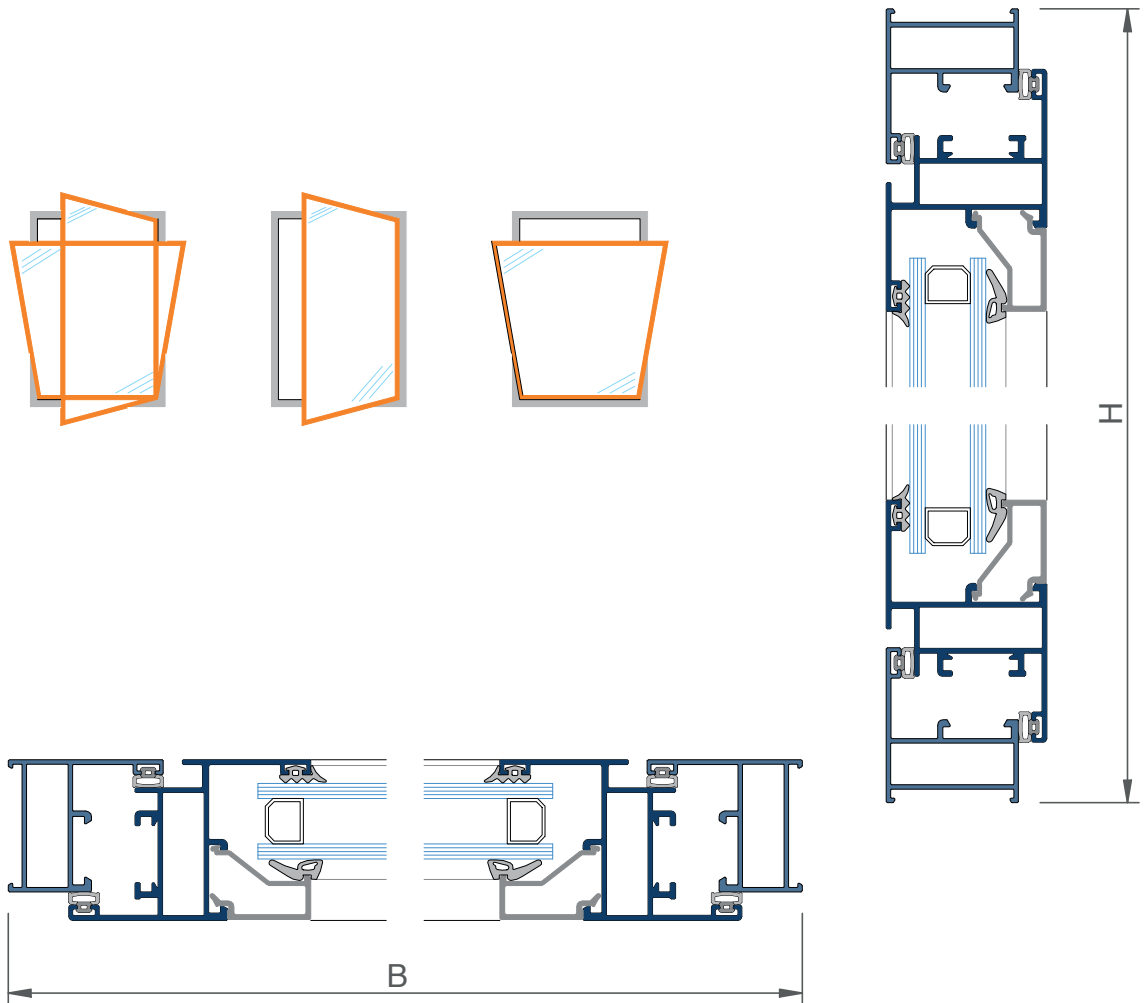

COD	DESCRIPCIÓN	CANT	FORMULA
AF35 4110	marco horizontal	2	B
AF35 4110	marco vertical	2	H
AF35 4220	hoja EXT horizontal	2	B-33
AF35 4220	hoja EXT vertical	2	H-33
A000 45xx	junquillo horizontal	2	B-116
A000 45xx	junquillo vertical	2	H-160
	vidrio	1	B-135 x H-135
A000 2112	escuadras	8	
A000 2320	junta cierre	4	B+H
A000 2351	junta ext vidrio	2	B+H
A000 2....	junta int vidrio	2	B+H

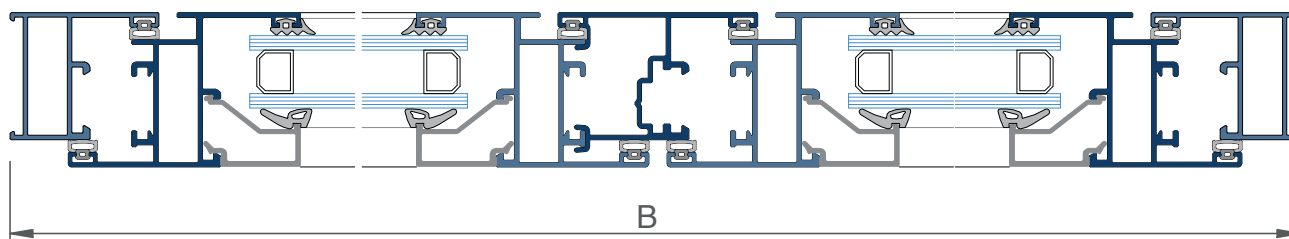
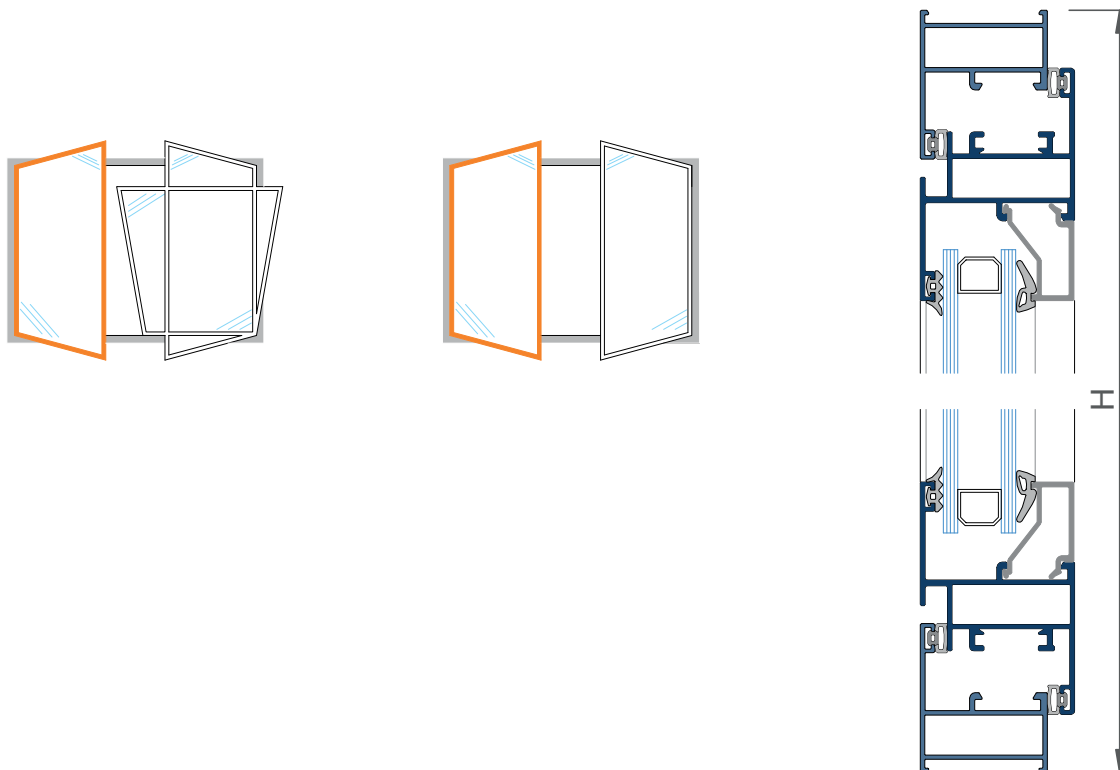

<i>COD</i>	<i>DESCRIPCIÓN</i>	<i>CANT</i>	<i>FORMULA</i>
AF35 4110	marco horizontal	2	B
AF35 4110	marco vertical	2	H
AF35 4220	hoja horizontal	4	$(B-38)/2$
AF35 4220	hoja vertical	4	H-33
AF35 4241	inversor doble hoja	1	H-96
A000 45xx	junquillo horizontal	4	$(B-204)/2$
A000 45xx	junquillo vertical	4	H-154
	vidrio	2	$(B-245)/2 \times H-135$
A000 2112	escuadras	12	
A000 2320	junta cierre	1	4B + 8H
A000 2351	junta ext vidrio	1	2B + 4H
A000 2....	junta int vidrio	1	2B + 4H
AF35 2340	juego tapas inversor	1	

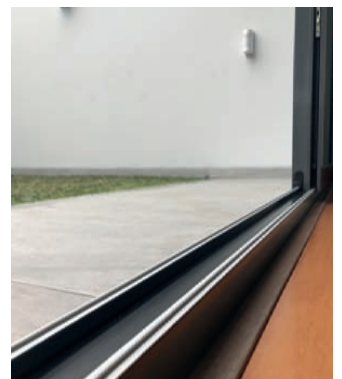
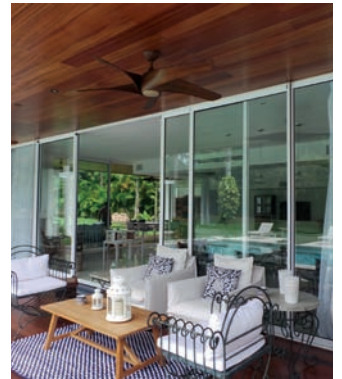
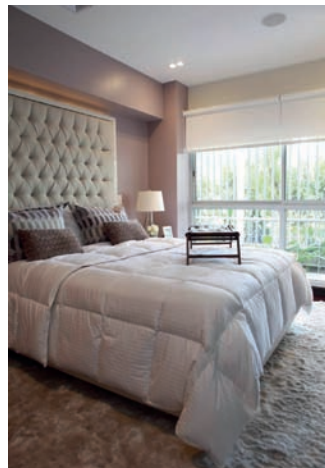
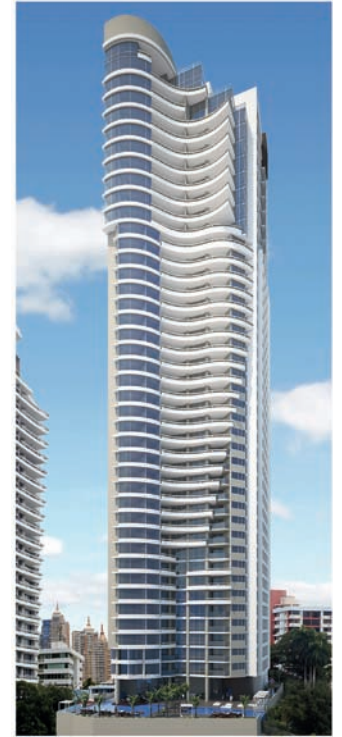
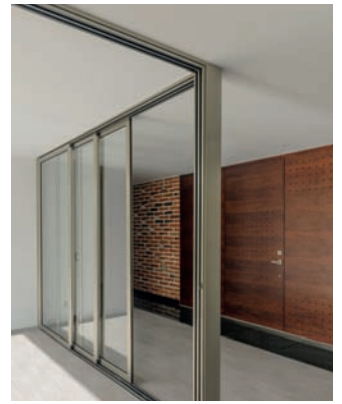
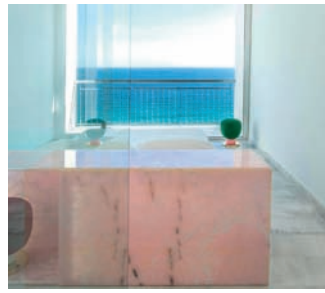

THERMIA®

B A R C E L O N A

Ventanas para vivir mejor

Sede Central en Barcelona

C/ Narcís Monturiol, 34
08192 Sant Quirze del Vallès
Barcelona (España)
Tel. +34 937 121 237
contacto@thermiabarcelona.com
Síguenos en   

Delegación Área Andina

Los Telares, 289
Urbanización Industrial Vulcano
Ate, Lima (Perú)
Tel. +51-1-7197649

Showrooms

Barcelona

Narcís Monturiol, 34
08192 Sant Quirze Valles
Tel. +34 937 121 237

Lima

Paseo de la República, 3583
2o. Piso - San Isidro
Tel. +51-1-7197649

Girona

Carrer Sant Jordi, 2
Local 4 - Sarrià de Ter
Tel. +34 937 121 237

THERMIABARCELONA.COM