

# SERIE THERMIA OC78+ C16

Más luminosidad con menos sección.

**THE** Diseño.  
Confort.  
Silencio.

**THERMIA**<sup>®</sup>  
BARCELONA

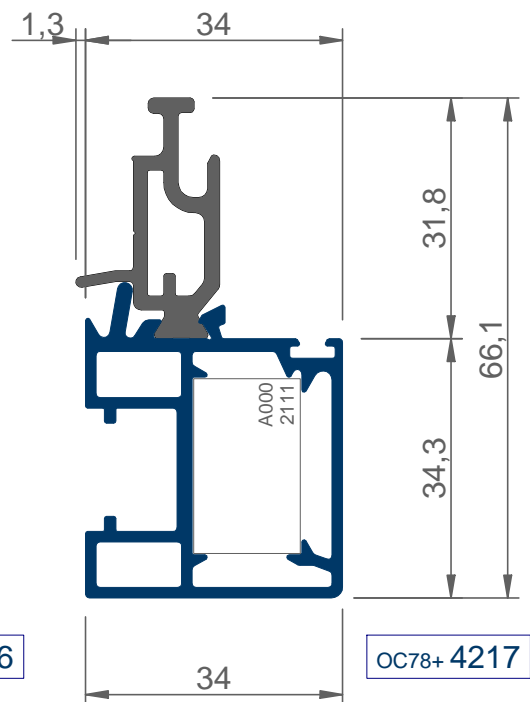
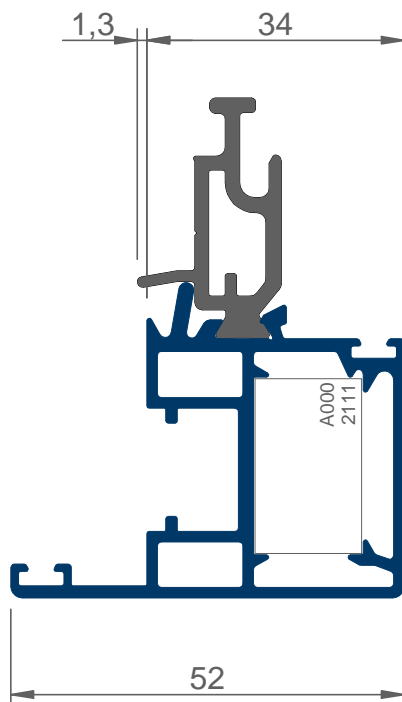
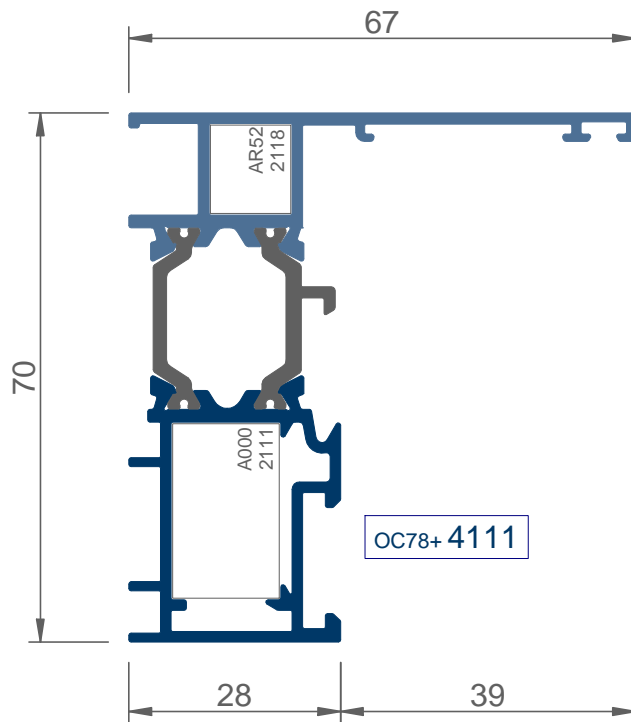

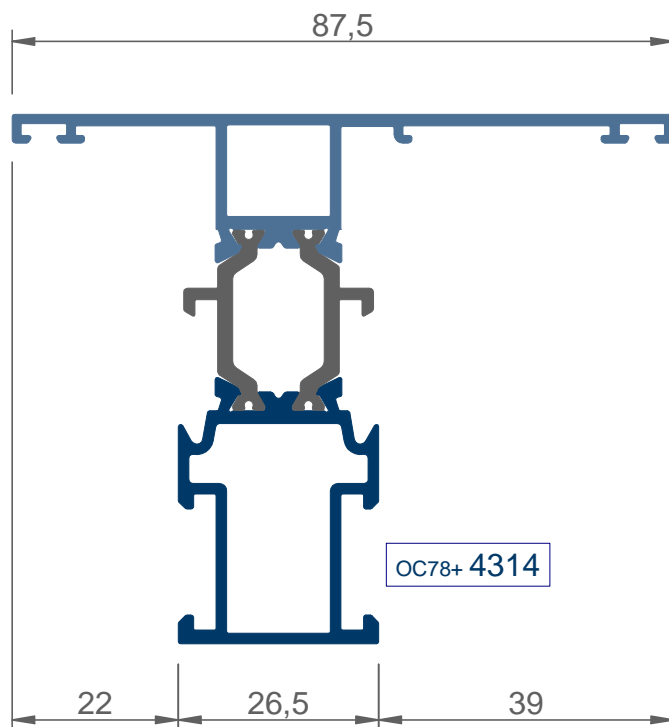
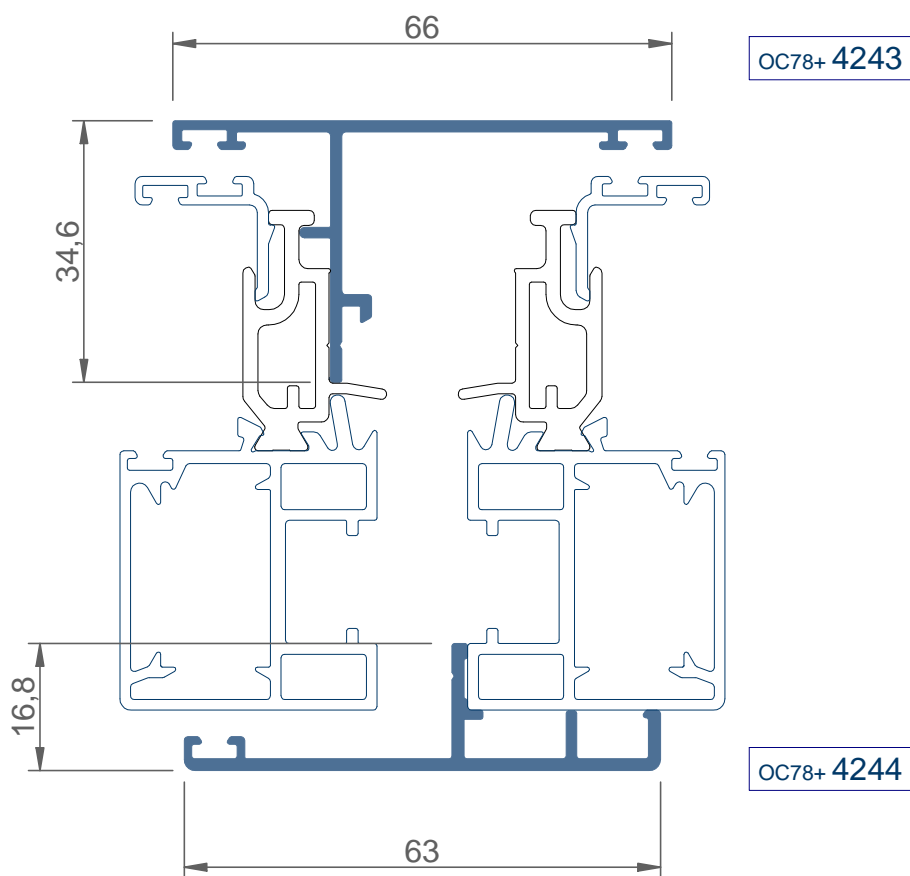

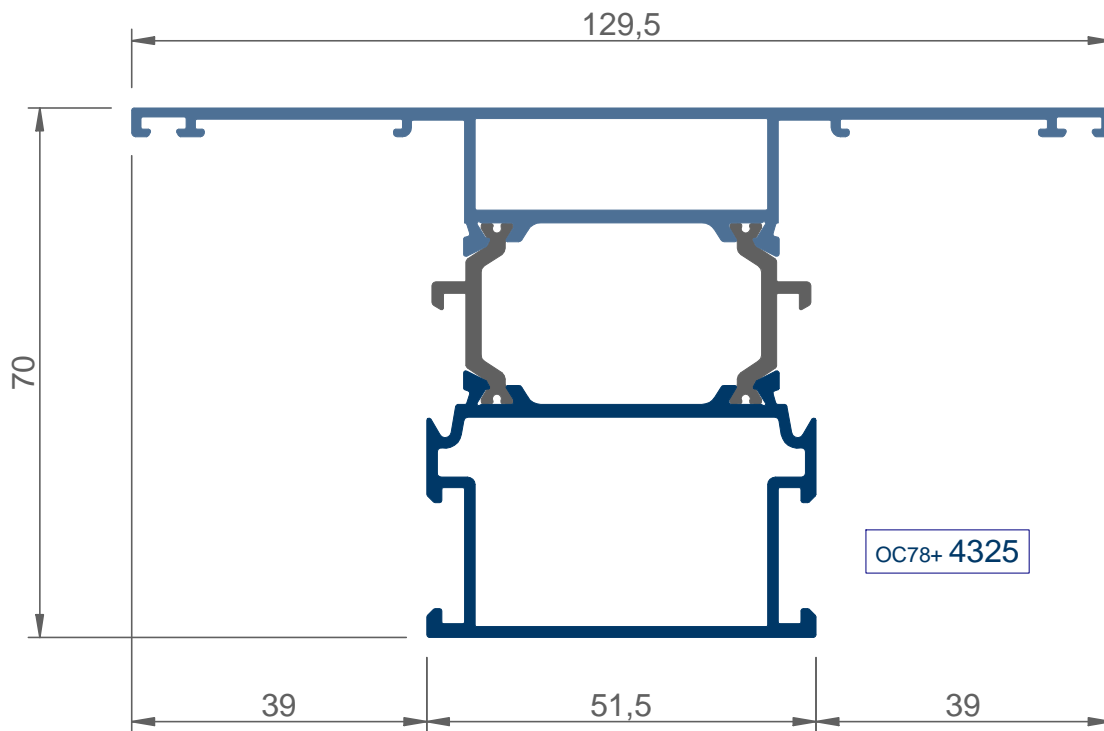
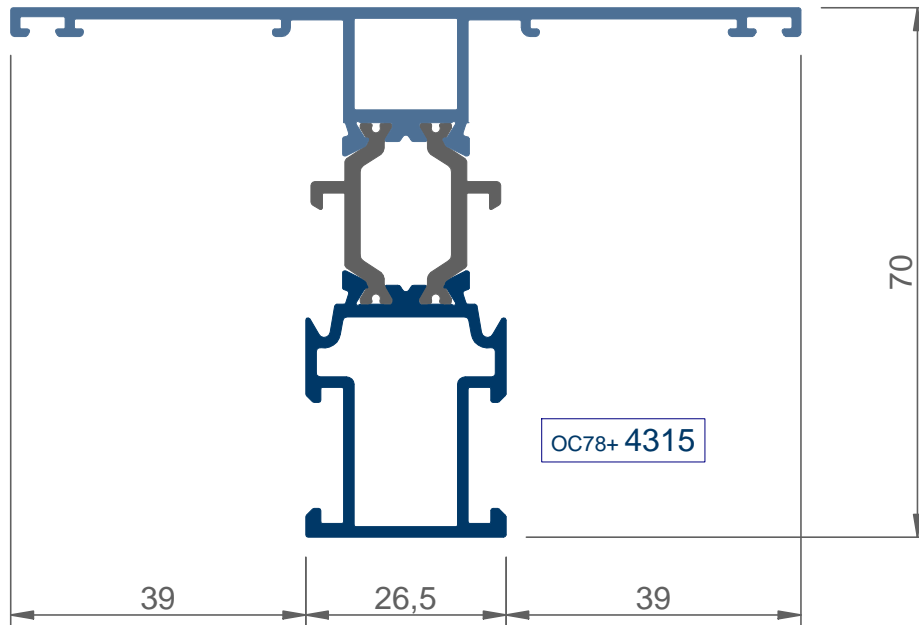

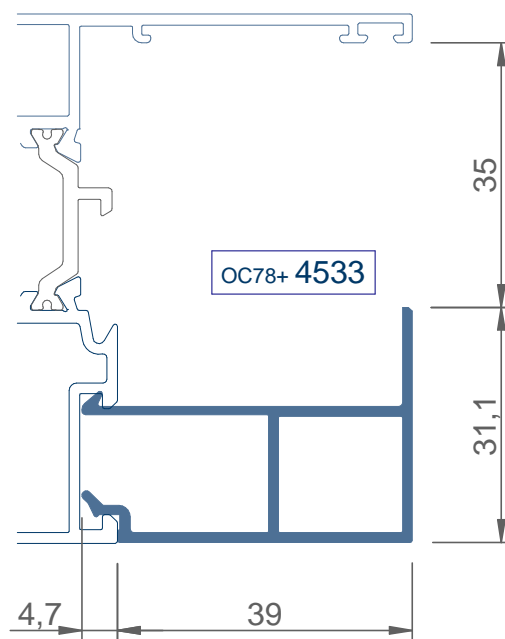
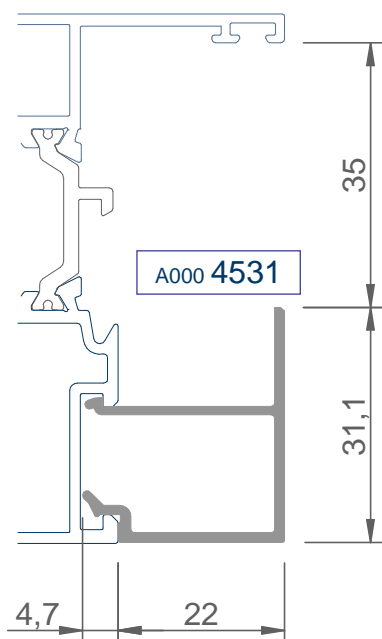
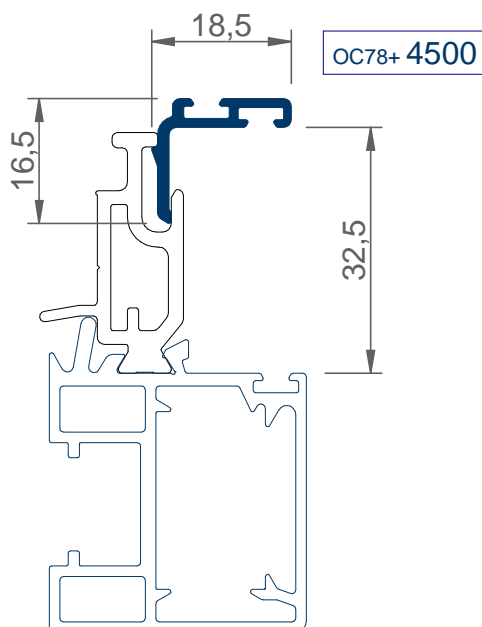

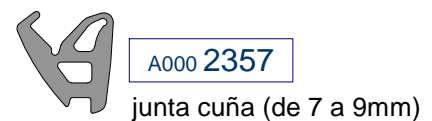
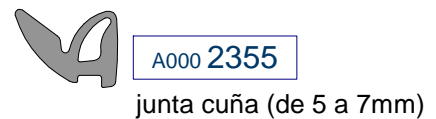
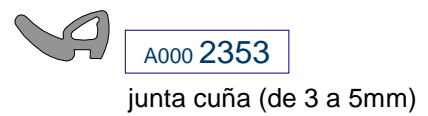
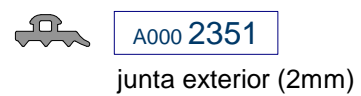
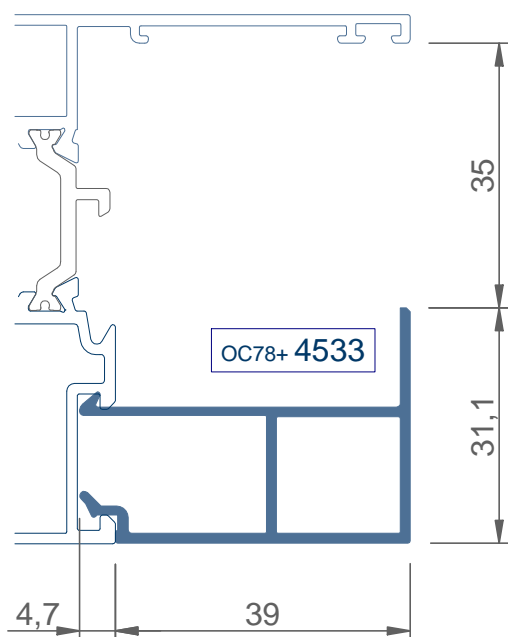
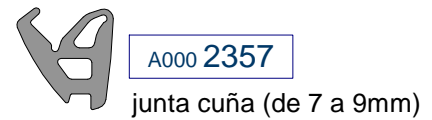
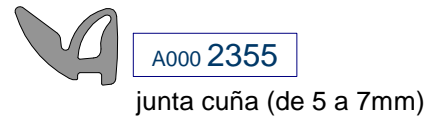
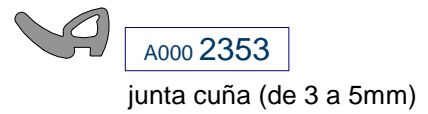
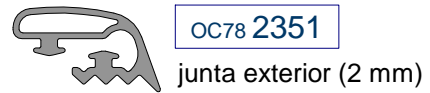
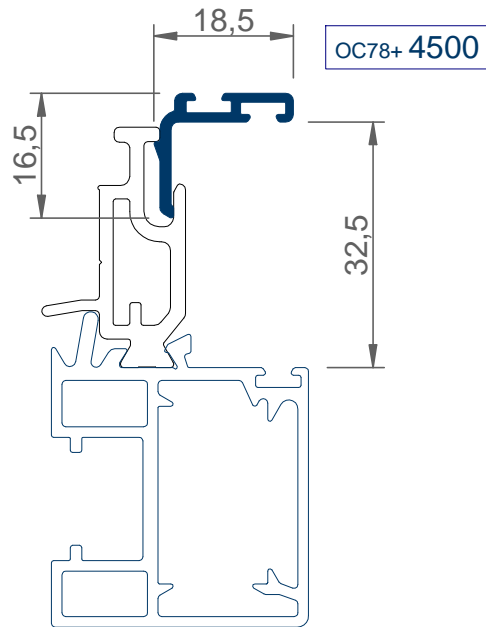



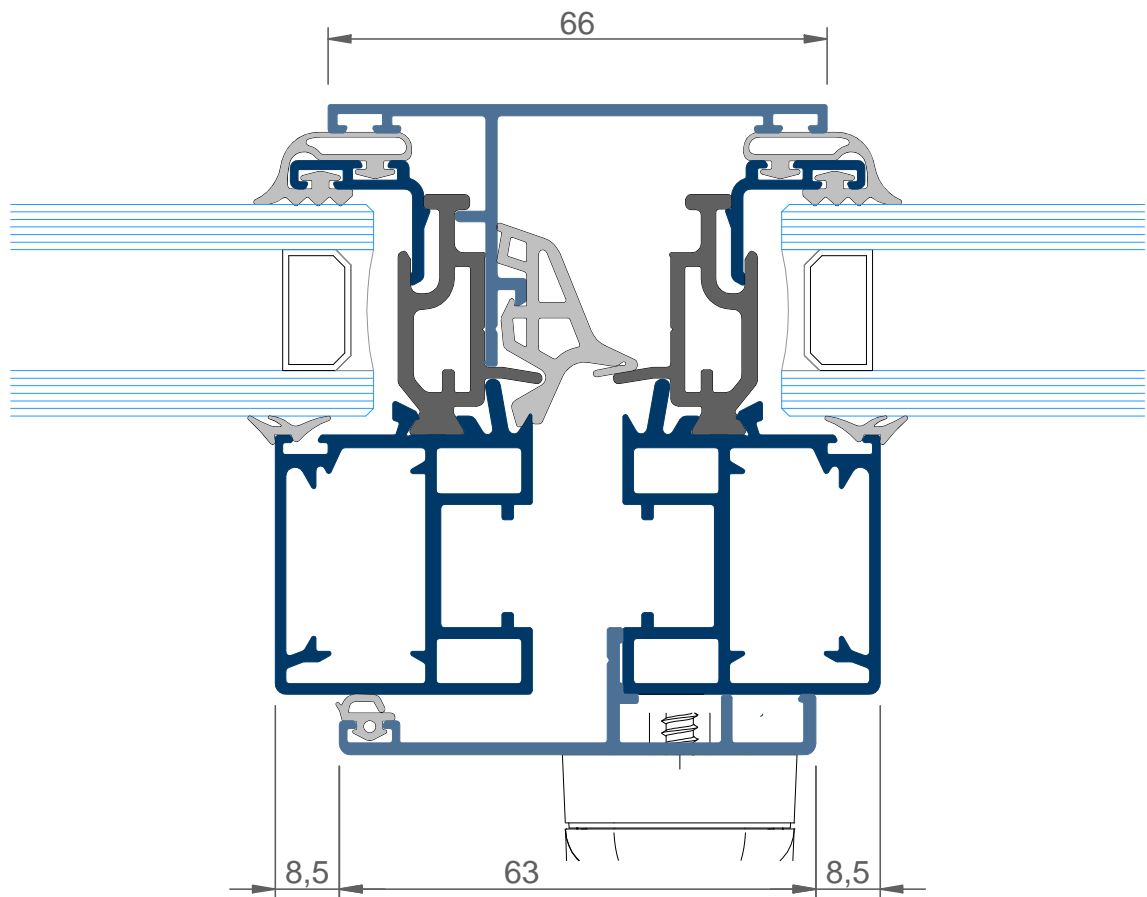
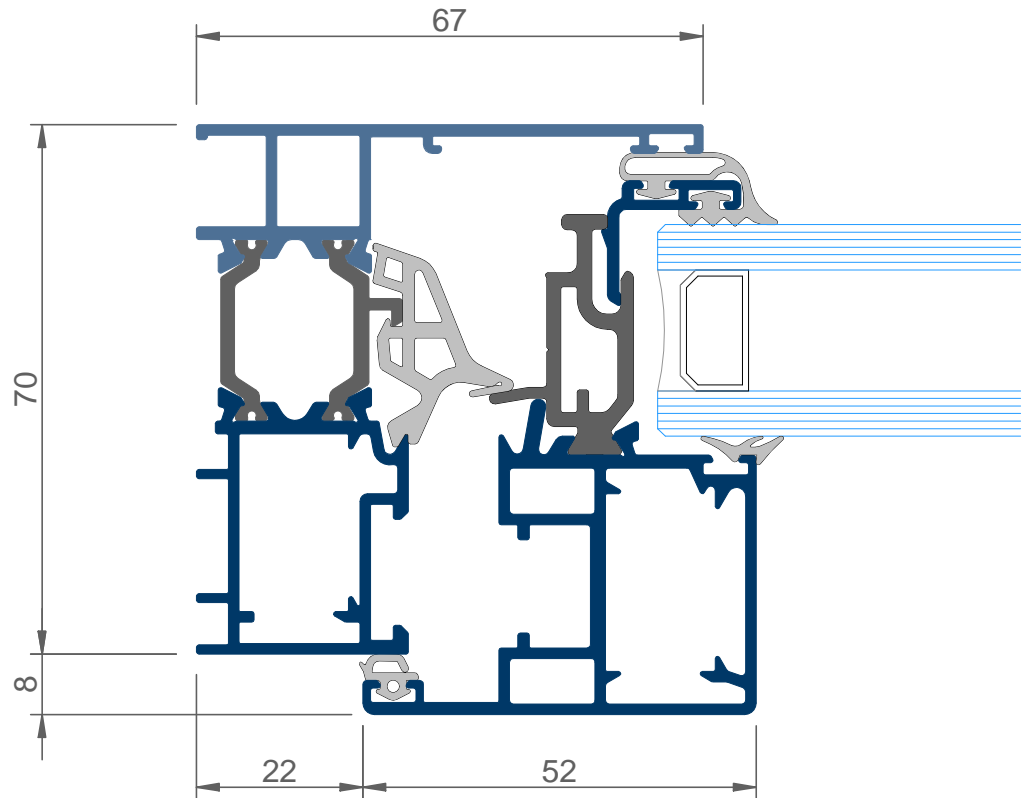



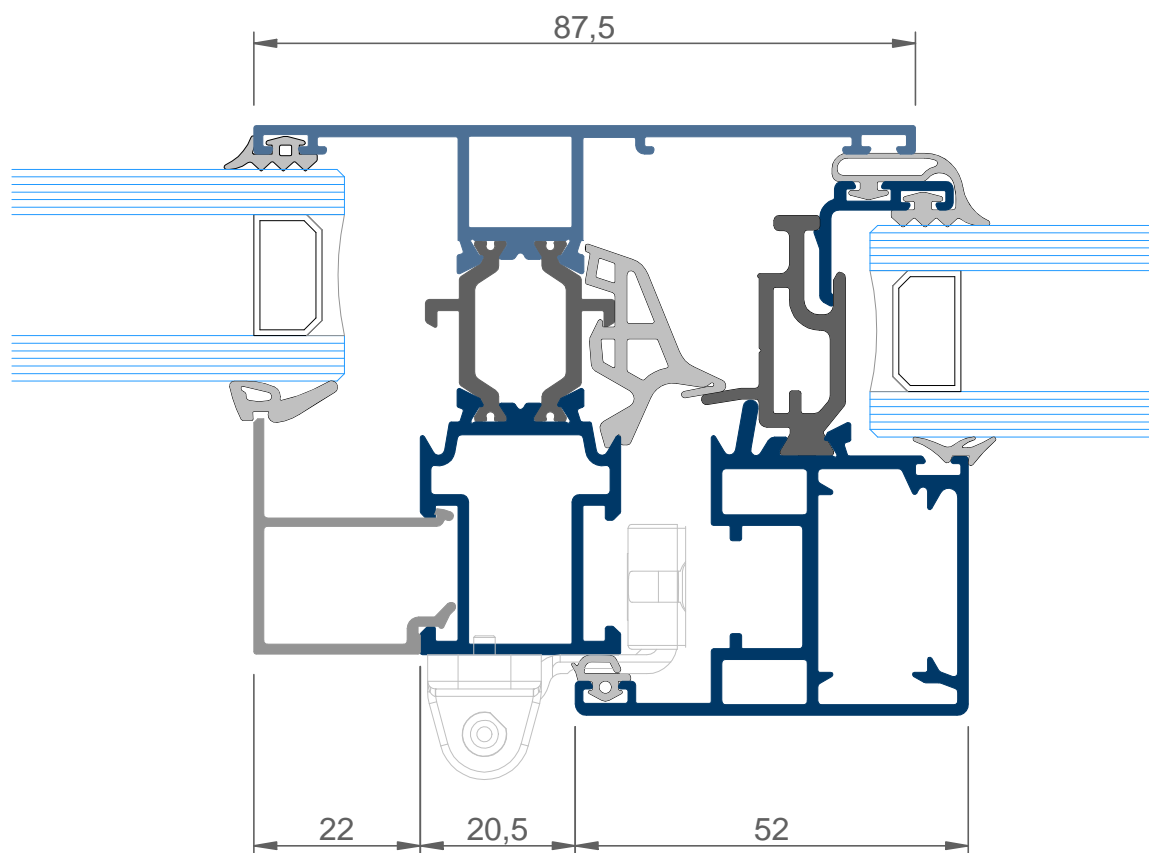
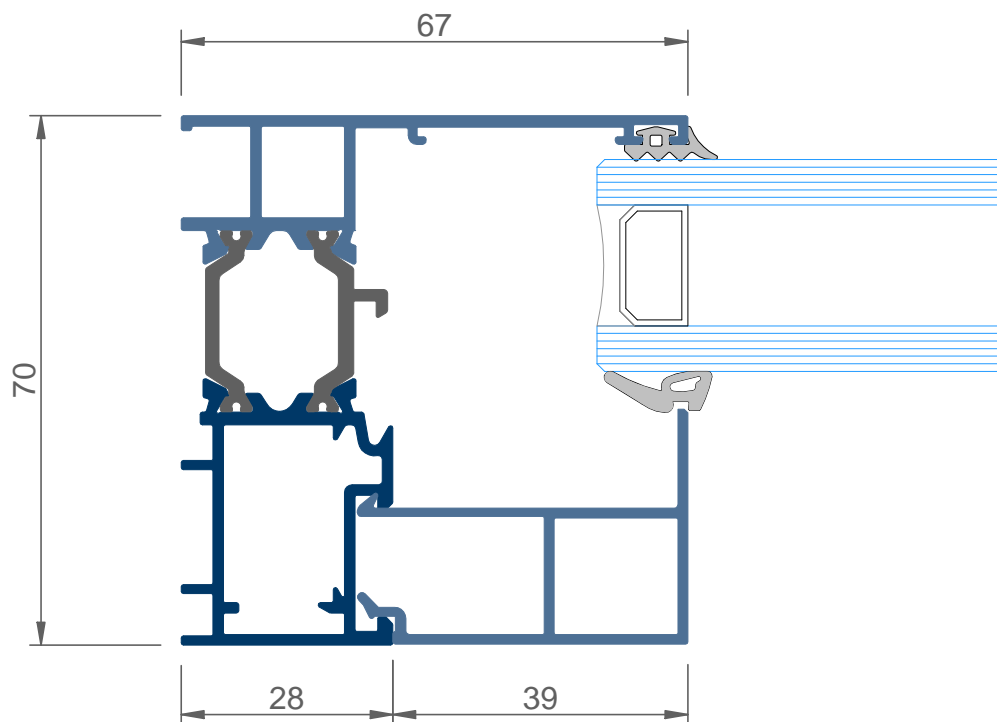

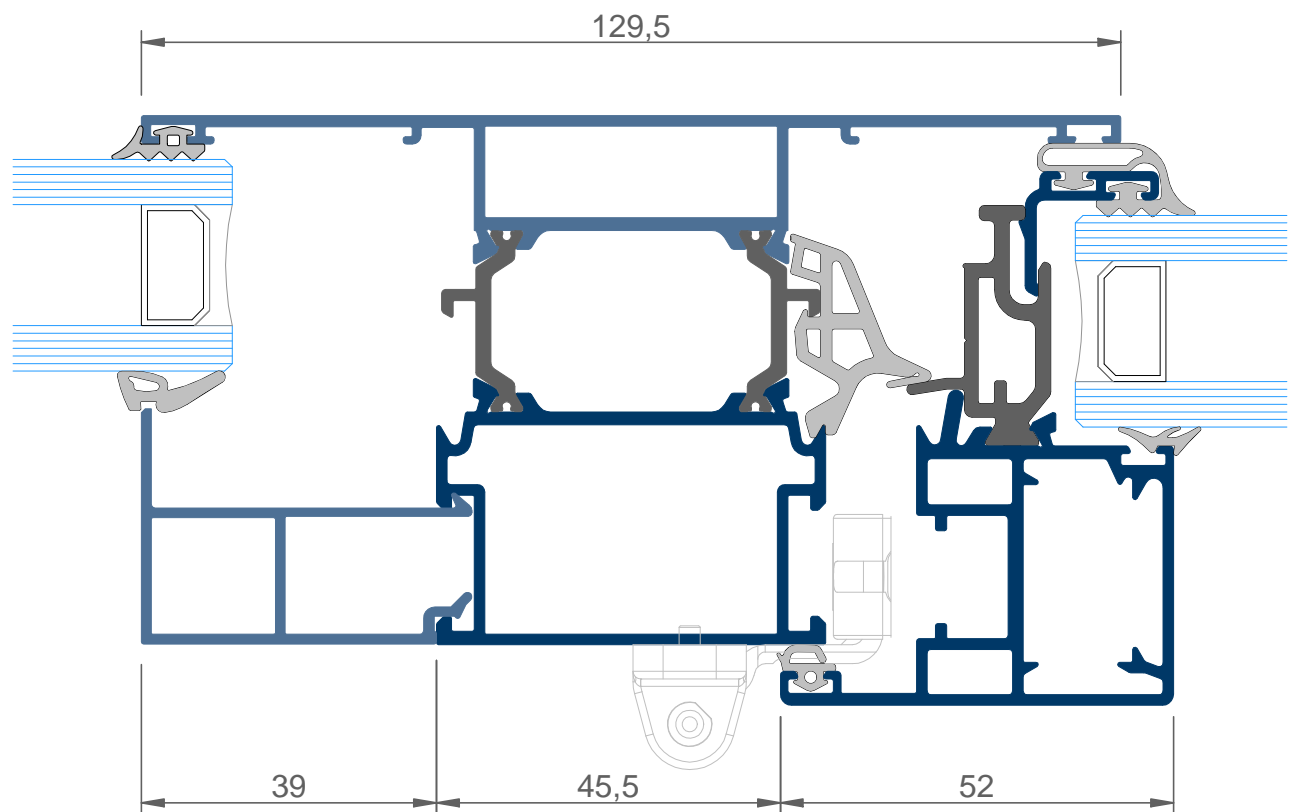
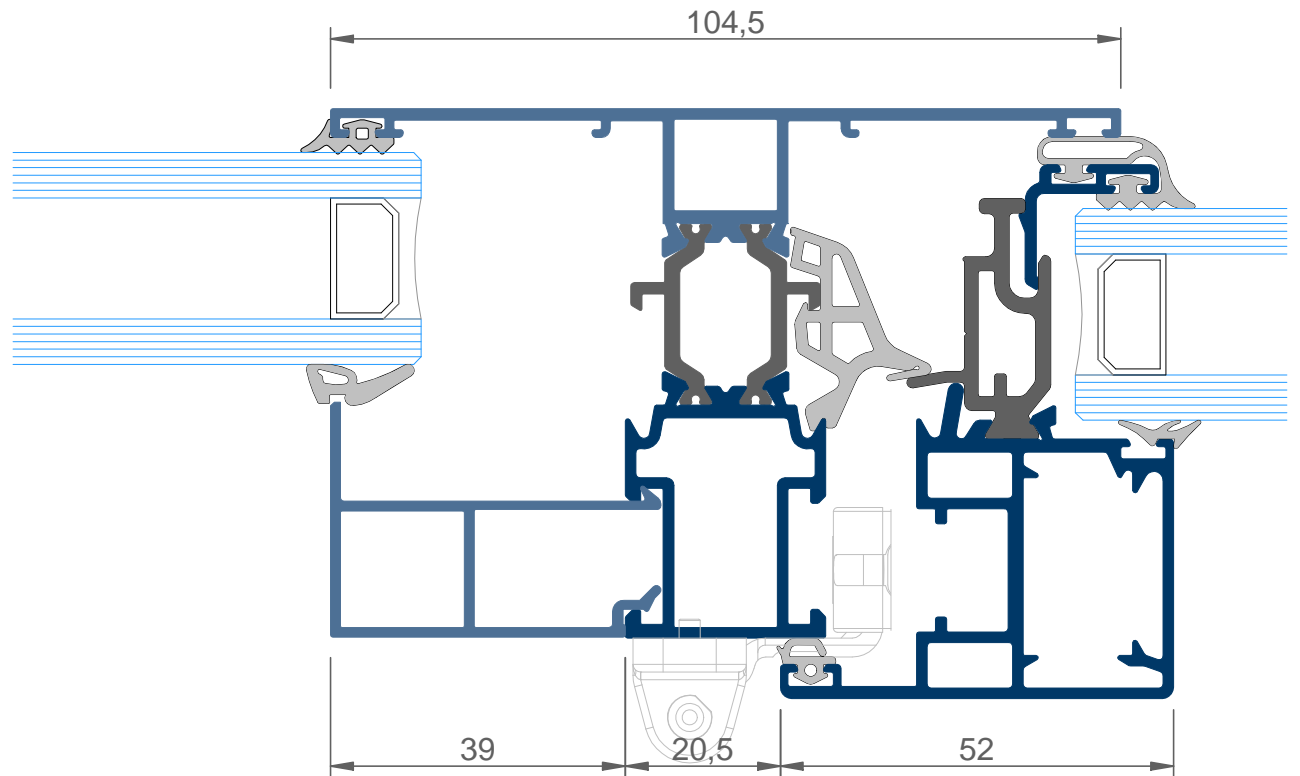

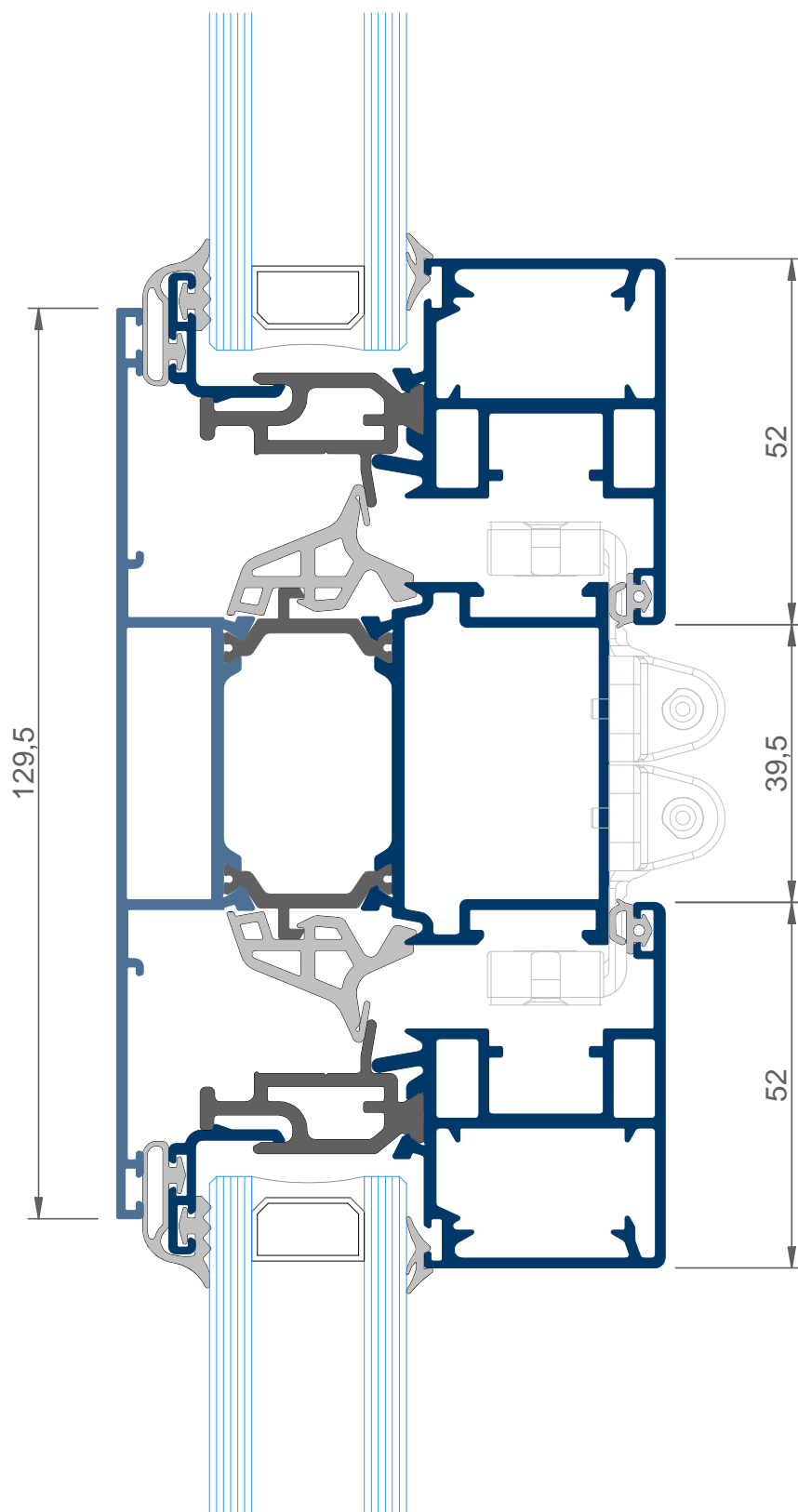

GIRAR PÁGINA PARA UNA CORRECTA LECTURA

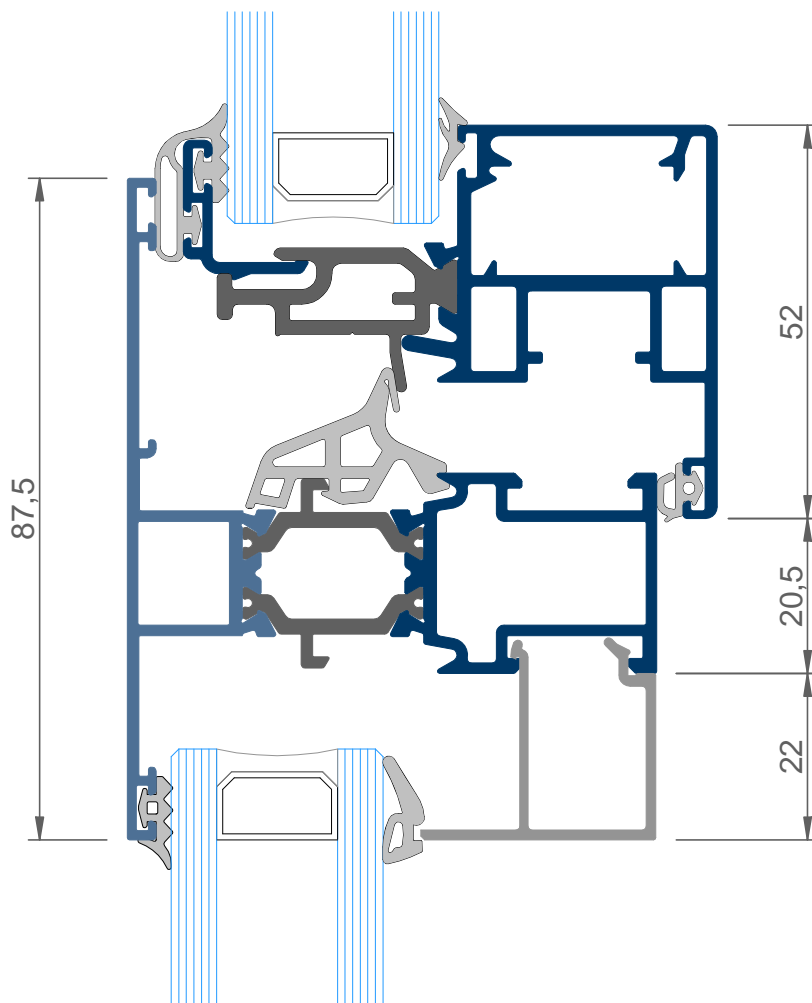
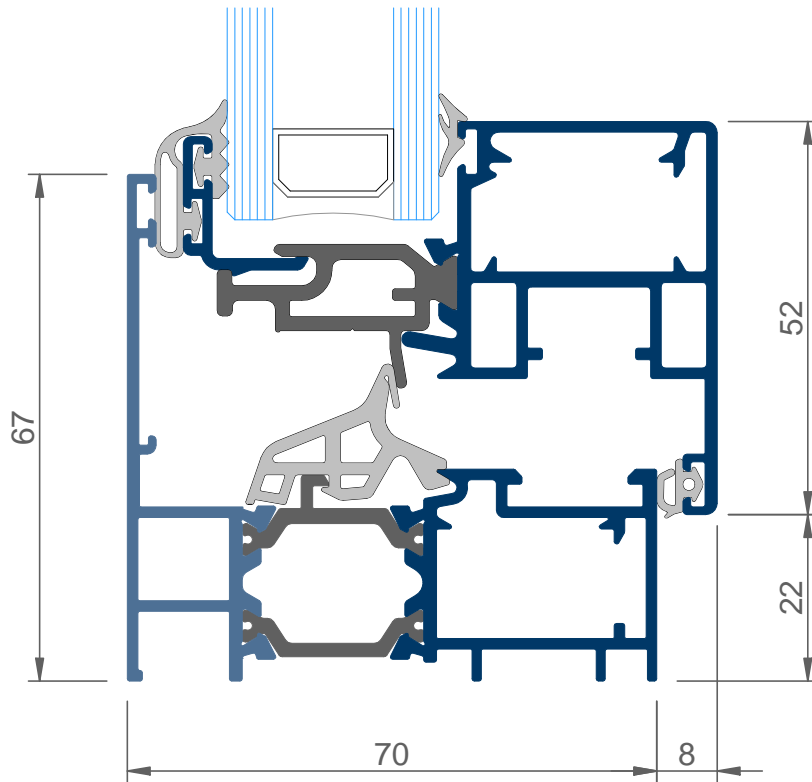

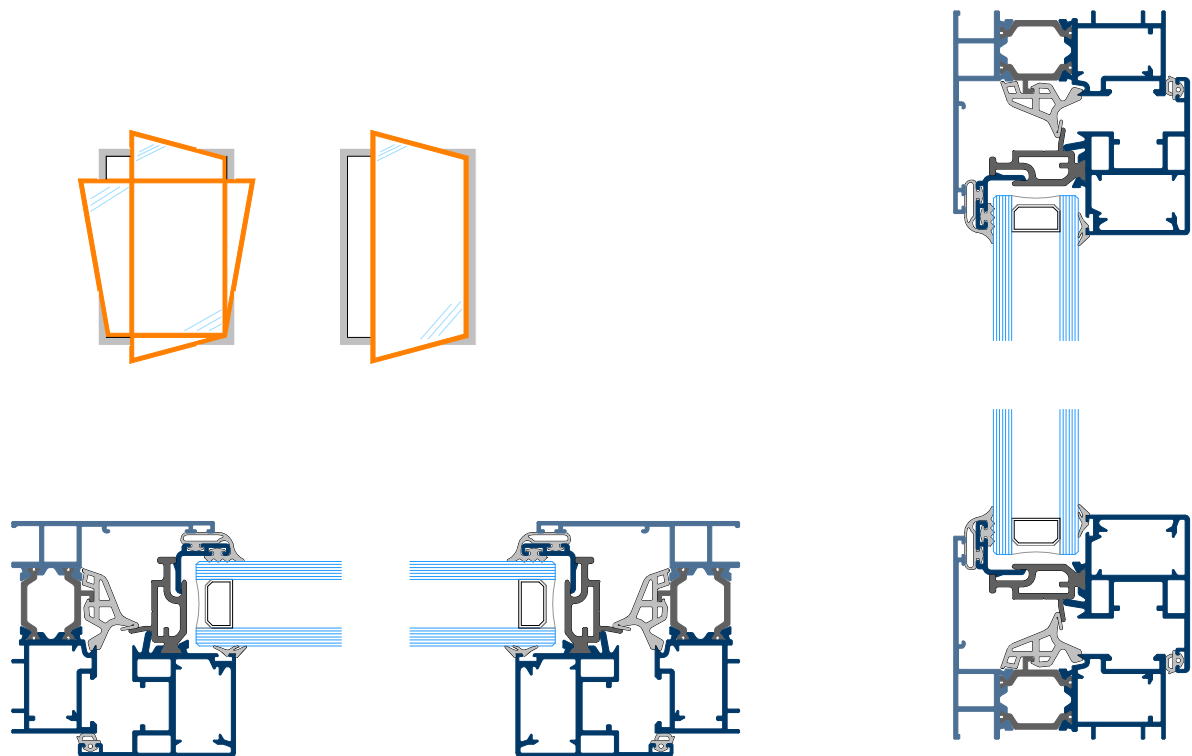

COD	DESCRIPCIÓN	CANT	FORMULA
OC78 4111	marco horizontal	2	B
OC78 4111	marco vertical	2	H
OC78 4216	hoja horizontal	2	B-45
OC78 4216	hoja vertical	2	H-45
OC78 4500	junquillo horizontal	2	B-107
OC784500	junquillo vertical	2	H-107
vidrio		1	B-122 x H-122
A000 2111	escuadras	8	
AR52 2118	escuadra ext marco	4	
A000 2301	tapa desagüe	2	
OC78 2307	junta central	2	B+H
A000 2320	junta cierre hoja	2	B+H
OC72 2351	junta ext vidrio	2	B+H
A000 235x	junta int vidrio	2	B+H

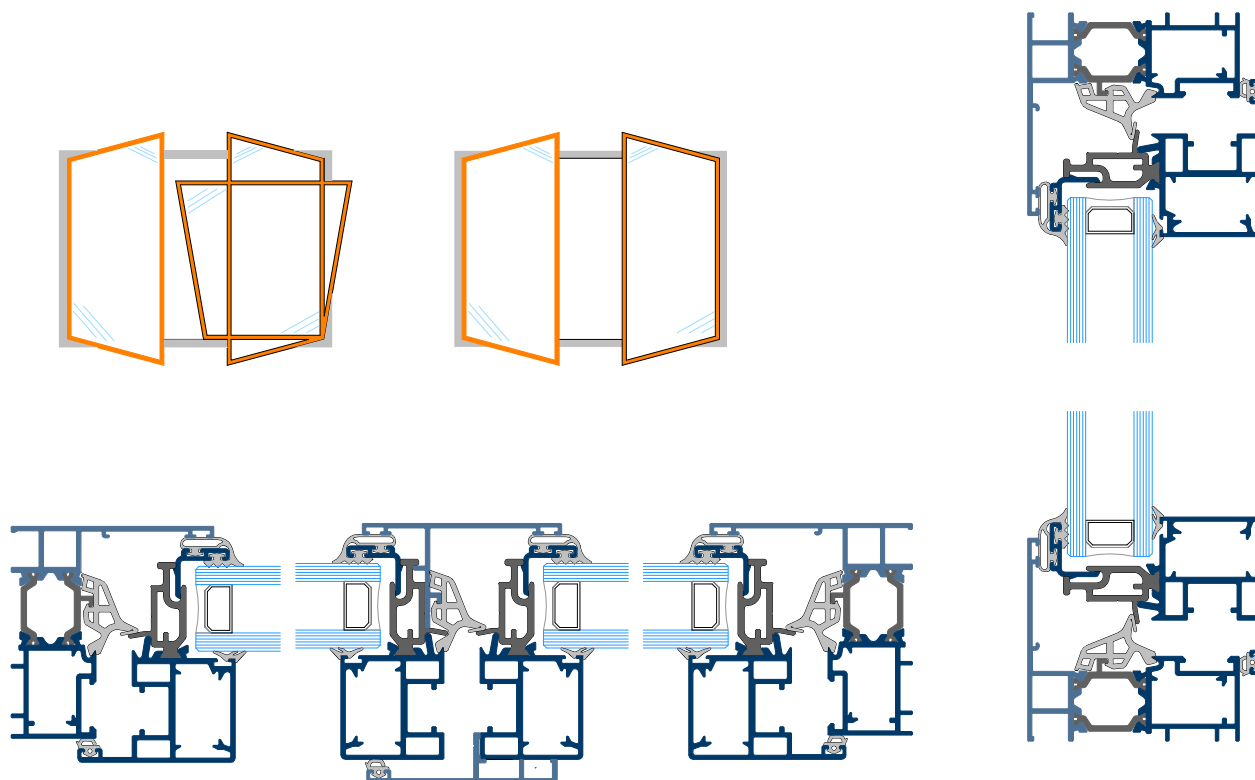

COD	DESCRIPCIÓN	CANT	FORMULA
OC78 4111	marco horizontal	2	B
OC78 4111	marco vertical	2	H
OC78 4216	hoja horizontal	4	$(B-20)/2$
OC78 4216	hoja vertical lateral	2	H-45
OC78 4217	hoja vertical central	2	H-81
OC78 4243	compl inversor exterior	1	H-143
OC78 4344	compl inversor interior	1	H-46
OC78 4500	junquillo horizontal	4	$(B-146)/2$
OC78 4500	junquillo vertical	4	H-107
	vidrio	2	$(B-176)/2 \times H-122$

A000 2111	escuadras	12	
AR52 2118	escuadra ext marco	4	
OC78 2340	juego tapas estanq inversor	1	
OC78 2341	juego tapas terminales inv	1	
A000 2301	tapa desagüe	3	
OC78 2307	junta central	1	$2B + 3H$
A000 2320	junta cierre hoja	1	$2B + 3H$
OC72 2351	junta ext vidrio	1	$2B + 4H$
A000 235x	junta int vidrio	1	$2B + 4H$

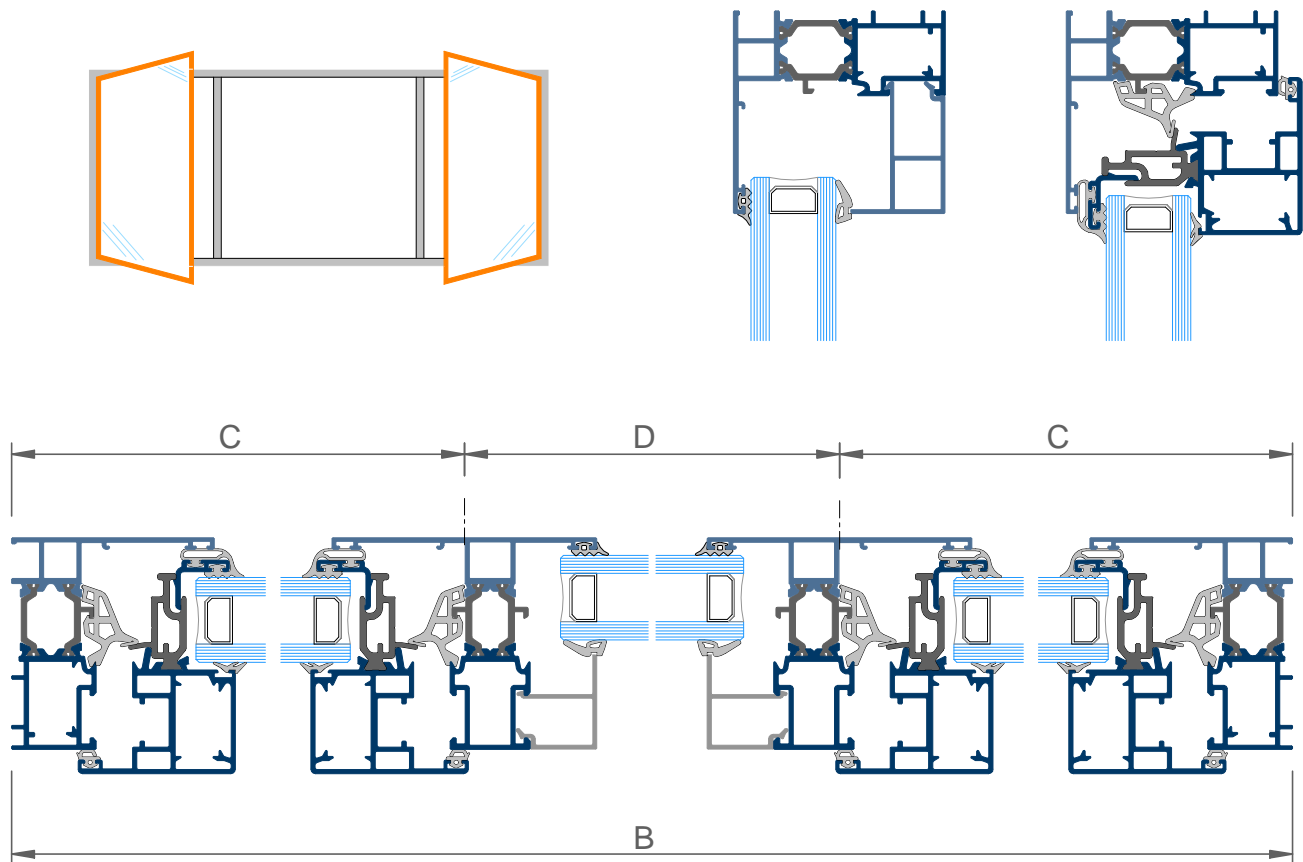

COD	DESCRIPCIÓN	CANT	FORMULA
OC78 4111	marco horizontal	2	B
OC78 4111	marco vertical	2	H
OC78 4216	hoja horizontal	4	C-24
OC78 4216	hoja vertical	4	H-45
OC78 4314	montante medio	2	H-47
OC78 4533	junquillo horizontal (parte fija)	2	D-43
A000 4533	junquillo vertical (parte fija)	2	H-134
OC78 4500	junquillo horizontal hoja	4	C-84
OC78 4500	junquillo vertical hoja	4	H-107
	vidrio hojas	2	C-98 x H-122
	vidrio fijo	1	D-63 x H-110

A000 2111	escuadras	12	
AR52 2118	escuadra ext marco	4	
A000 2120	pieza unión montante	4	
OC72 2145	escuadra alin montante	4	
A000 2301	tapa desagüe	5	
OC78 2307	junta central	1	4C + 4H
A000 2320	junta cierre hoja	1	4C + 4H
OC72 2351	junta ext vidrio hoja	1	4C + 4H
A000 235x	junta int vidrio	1	4C + 4H